

| Basel Bad Bf - Riehen | | Basel Bad Bf - Grenzach | |
|-----------------------|-----|-------------------------|-----|
| P2B | | GNT+P2B | |
| Hauptbahn | | Hauptbahn | |
| 120 | | 130 > 160 < | |
| 400 | | 400 | |
| 2,6 | 0,9 | 2,5 | 2,4 |
| 3,0 | 1,3 | 2,7 | 2,4 |
| 4,3 | 1,3 | 2,7 | 2,6 |

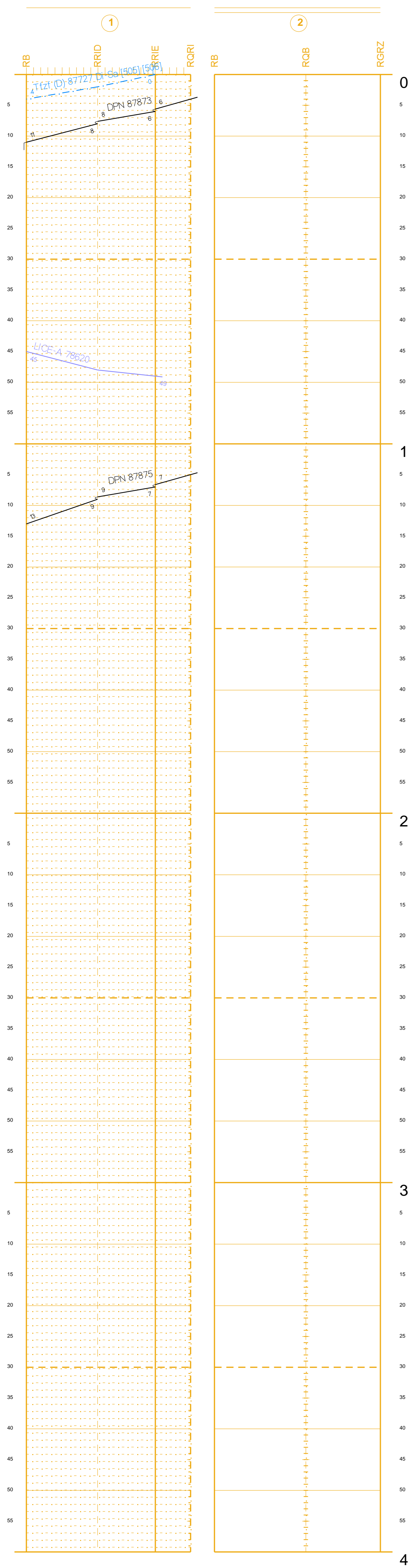

| Basel Bad Bf - Riehen | | Basel Bad Bf - Grenzach | |
|-----------------------|-----|-------------------------|-----|
| P2B | | GNT+P2B | |
| Hauptbahn | | Hauptbahn | |
| 120 | | 130 > 160 < | |
| 400 | | 400 | |
| 2,6 | 0,9 | 2,5 | 2,4 |
| 3,0 | 1,3 | 2,7 | 2,4 |
| 4,3 | 1,3 | 2,7 | 2,6 |

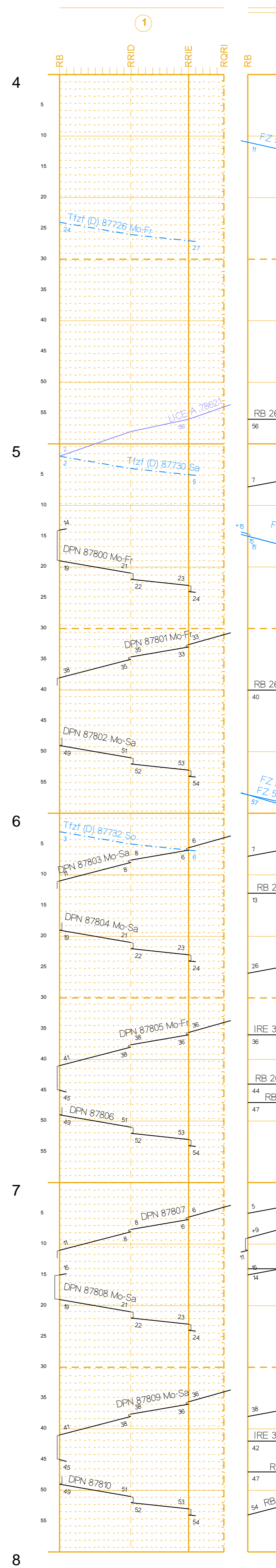

| Basel Bad Bf - Riehen | | Basel Bad Bf - Grenzach | |
|-----------------------|-----|-------------------------|-----|
| P2B | | GNT+P2B | |
| Hauptbahn | | Hauptbahn | |
| 120 | | 130 > 160 < | |
| 400 | | 400 | |
| 2,6 | 0,9 | 2,5 | 2,4 |
| 3,0 | 1,3 | 2,7 | 2,4 |
| 4,3 | 1,3 | 2,7 | 2,6 |

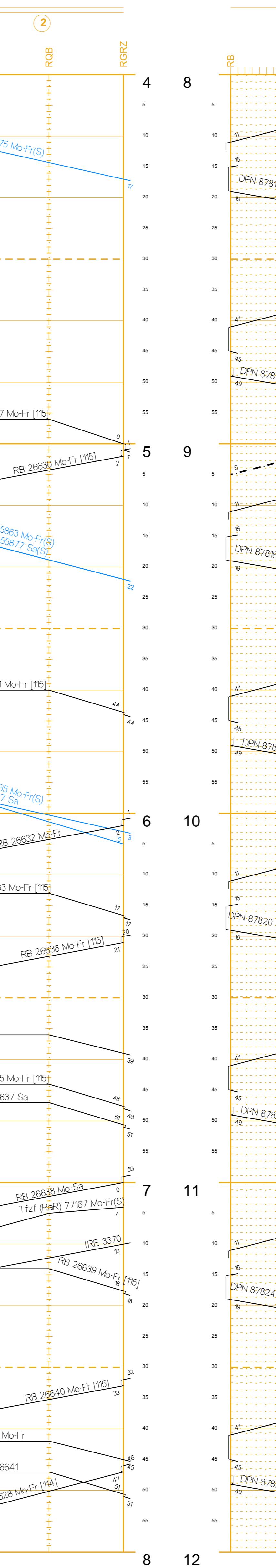

| Basel Bad Bf - Riehen | | Basel Bad Bf - Grenzach | |
|-----------------------|-----|-------------------------|-----|
| P2B | | GNT+P2B | |
| Hauptbahn | | Hauptbahn | |
| 120 | | 130 > 160 < | |
| 400 | | 400 | |
| 2,6 | 0,9 | 2,5 | 2,4 |
| 3,0 | 1,3 | 2,7 | 2,4 |
| 4,3 | 1,3 | 2,7 | 2,6 |

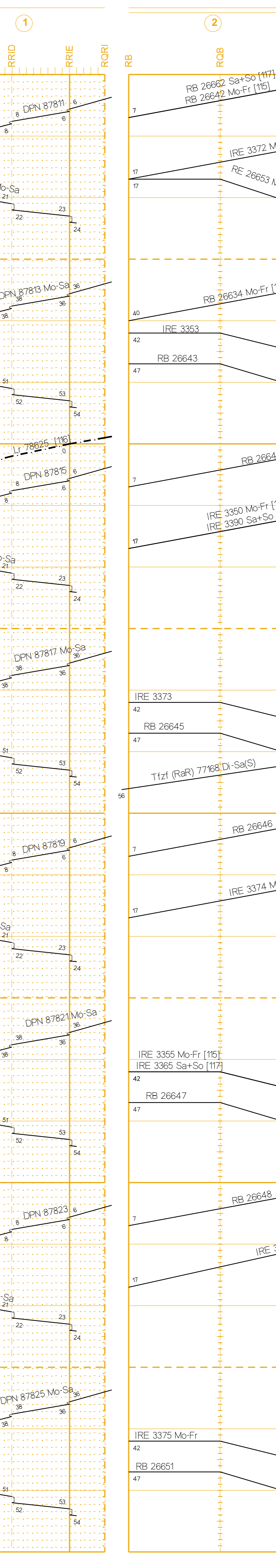

[114] 12.9.11 - 10.12.11 Mo-Fr nicht: 3.10.11, 1.11.11
 [115] nicht: 3.10.11, 1.11.11
 [116] 4.9.11 - 31.10.11 nicht: 4.10.11, 5.10.11, 11.10.11, 12.10.11, 18.10.11, 19.10.11, 20.10.11, 25.10.11, 26.10.11, 27.10.11
 [117] 1.11.11 - 10.12.11 Sa auch: 3.10.11, 1.11.11
 [505] nicht: 4.10.11, 2.11.11
 [506] nicht: 3.10.11, 1.11.11

Fahrpläne Basel Ost ab 04.09.2011

Stunden: 12 - 24

Niederlassung Südwest

Jahresfahrplan 2011 vom: 12. Dezember 2010 bis: 10. Dezember 2011
Gültig vom: 04. September 2011 bis: 10. Dezember 2011 / täglich

Fahrpläne Basel Ost ab 04.09.2011

Stunden: 12 - 24

| | | | | |
|-----------------------|-----------|-----|-----|-----|
| Basel Bad Bf - Riehen | | | | |
| | P2B | | | |
| | Hauptbahn | | | |
| | 120 | | | |
| | 400 | | | |
| -1,8 | 2,6 | 0,8 | 2,2 | 3,0 |
| | | | | 4,3 |

| | | | | |
|-------------------------|-------------|-----|-----|-----|
| Basel Bad Bf - Grenzach | | | | |
| | GNT+P2B | | | |
| | Hauptbahn | | | |
| | 130 > 160 < | | | |
| | 400 | | | |
| 2,0 | 2,5 | 2,7 | 2,4 | |
| 2,0 | | | | 2,6 |

| | | | | |
|-----------------------|-----------|-----|-----|-----|
| Basel Bad Bf - Riehen | | | | |
| | P2B | | | |
| | Hauptbahn | | | |
| | 120 | | | |
| | 400 | | | |
| -1,8 | 2,6 | 0,8 | 2,2 | 3,0 |
| | | | | 4,3 |

| | | | | |
|-------------------------|-------------|-----|-----|-----|
| Basel Bad Bf - Grenzach | | | | |
| | GNT+P2B | | | |
| | Hauptbahn | | | |
| | 130 > 160 < | | | |
| | 400 | | | |
| 2,0 | 2,5 | 2,7 | 2,4 | |
| 2,0 | | | | 2,6 |

| | | | | |
|-----------------------|-----------|-----|-----|-----|
| Basel Bad Bf - Riehen | | | | |
| | P2B | | | |
| | Hauptbahn | | | |
| | 120 | | | |
| | 400 | | | |
| -1,8 | 2,6 | 0,8 | 2,2 | 3,0 |
| | | | | 4,3 |

| | | | | |
|-------------------------|-------------|-----|-----|-----|
| Basel Bad Bf - Grenzach | | | | |
| | GNT+P2B | | | |
| | Hauptbahn | | | |
| | 130 > 160 < | | | |
| | 400 | | | |
| 2,0 | 2,5 | 2,7 | 2,4 | |
| 2,0 | | | | 2,6 |

BAV 525

Basel Bad Bf

Riehen Niederholz Hp

Riehen

Riehen LGR

BAV 521 / 2

Basel Bad Bf

Basel Bad Bf LGR

Stk. 9093 / Stk. 9092

Grenzach

BAV 525

Basel Bad Bf

Riehen Niederholz Hp

Riehen

Riehen LGR

BAV 521 / 2

Basel Bad Bf

Basel Bad Bf LGR

Stk. 9093 / Stk. 9092

Grenzach

BAV 525

Basel Bad Bf

Riehen Niederholz Hp

Riehen

Riehen LGR

BAV 521 / 2

Basel Bad Bf

Basel Bad Bf LGR

Stk. 9093 / Stk. 9092

Grenzach

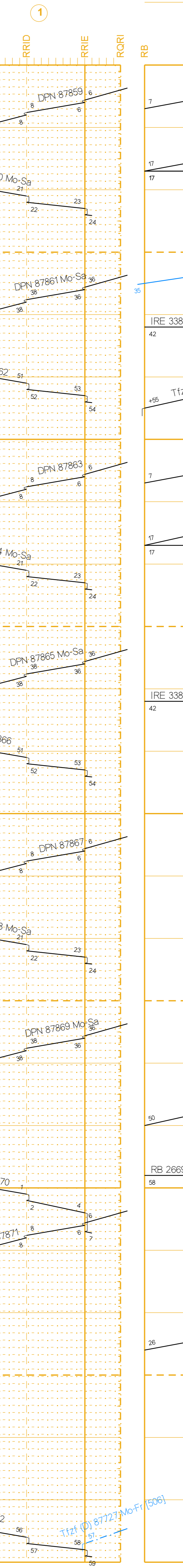
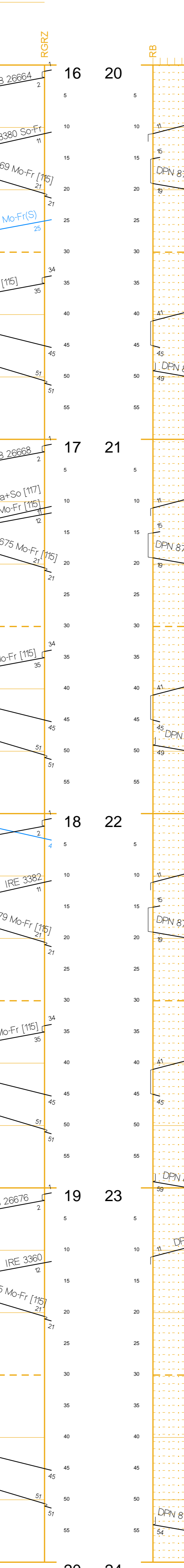
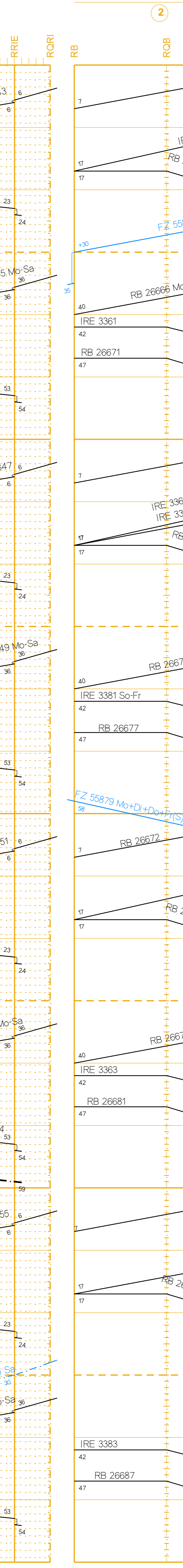
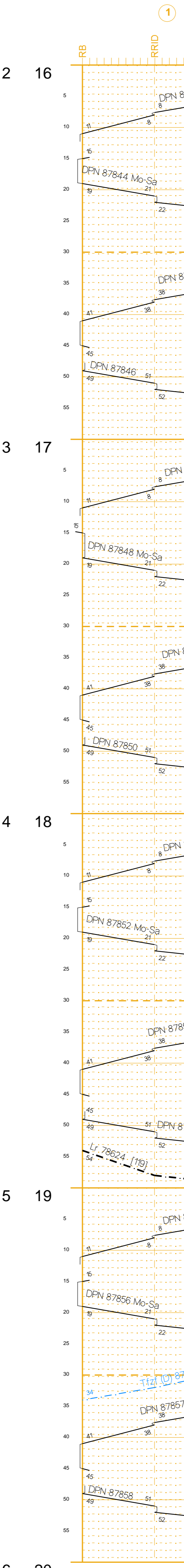
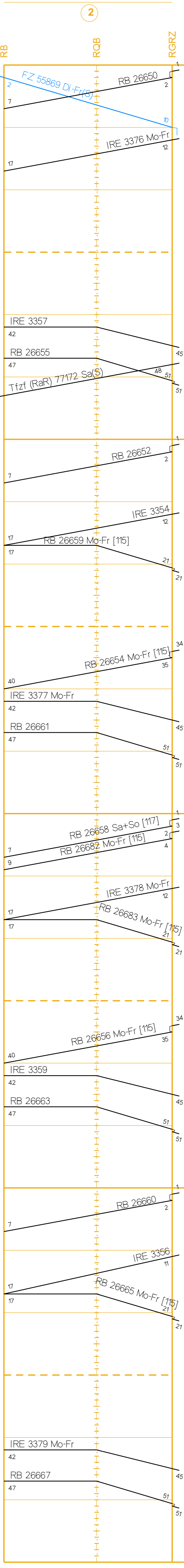
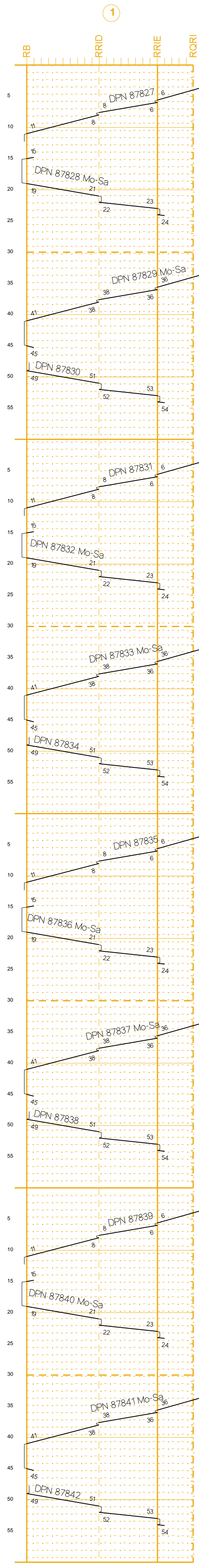

[115] nicht: 3.10.11, 1.11.11
auch: 3.10.11, 1.11.11
[117] 4.9.11 - 31.10.11
nicht: 4.10.11, 5.10.11, 11.10.11,
12.10.11, 18.10.11, 19.10.11,
20.10.11, 25.10.11, 26.10.11,
27.10.11
5.11.11 - 10.12.11 Sa

[506] nicht: 3.10.11, 1.11.11

Tzf (D) 87273 Mo-Fr [506]