

14 A
 0-6

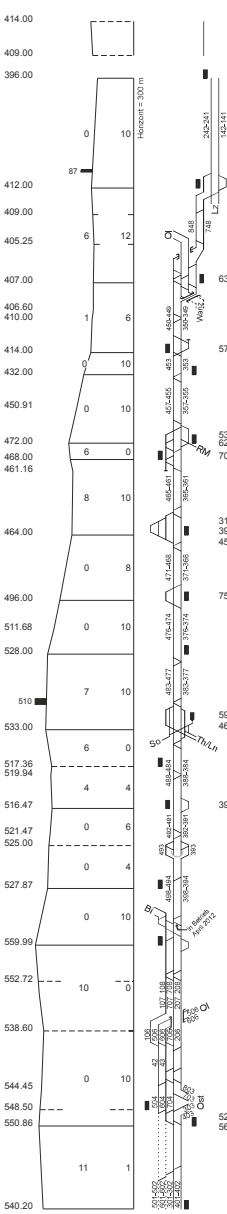

Aarburg-Oftringen Süd (Abzw)	00.83
Aarburg-Oftringen West (Abzw)	00.00
Olten	39.29
	3.71
Aarburg-Oftringen	43.01
Aarburg-Oftringen West (Abzw)	0.97
Bifang AG (Spw)	0.89
	1.34
Rothrist	46.20
Rothrist Hungerzelg Rank (Spw)	2.87
	3.15
Murgenthal Roggwil-Wynau	52.22
	2.27
<i>Gurtelen</i>	4.62
Langenthal Langenthal GB	59.11
Langenthal West (Abzw)	1.18
	59.19
	60.38
	0.88
	61.26
	5.46
	66.42
	66.50
	66.79
Herzogenbuchsee	66.79
	5.54
Riedwil	72.33
<i>Lochmatt</i>	4.60
Wynigen	76.93
	6.46
vin Solothurn	
Burgdorf	83.39
vin Hasle-Rüegsau	
	3.15
Lyssach Sandacher (Spw)	86.54
	0.66
	87.20
	2.53
Hindelbank	89.73
Hardfeld (Spw)	1.93
Mattstetten (Abzw)	0.32
	91.66
	0.32
	91.98
Schönbühl SBB	94.91
	2.93
vin Biel/Bienne	
Zollikofen	98.81
	3.89
Zollikofen West (Spw)	1.05
	99.86
	99.88
Löchligen	101.28
	1.40
	1.22
Löchligen Süd (Abzw)	102.50
	0.44
Bern Wankdorf Bern Wylersfeld	102.94
	0.39
	103.33
Lorraine Gl. 300/400	2.80
Bern	106.13

Höhen über Meer RPN = 373.60
 Längsprofil
 Grösste Steigung
 Grösstes Gefälle
 Stationen
 Abzweigungen
 Übergänge
 Grösste Ausweichweite

Blickstationen
 Bern JKL
 Bern
 Bern JKL
 Gleise P (J2,J7,J8)
 Gleise G (J1,M11)
 Entf. von Stat. zur Stat.
 Klammernung der Bahn

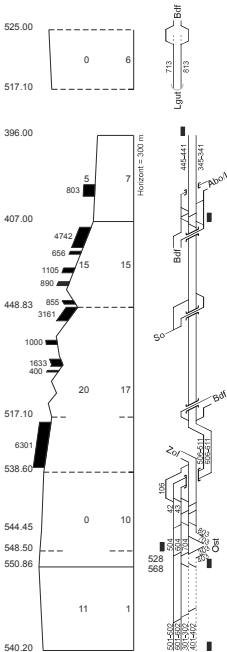

Bern Weyermannshaus	
Mattstetten (Abzw)	92.09
	0.68
Aespli	92.77
	12.28
Olten Nord-Ost (Abzw)	39.29
	5.86
Rothrist	45.15
vin Burgdorf	46.20
	47.35
	53.29
	19.39
Wanzwil (Abzw)	36.98
vin Solothurn	
	24.71
vin Burgdorf	
Aespli	12.28
	7.43
Löchligen	4.85
	101.28
	1.22
Löchligen Süd (Abzw)	102.50
	0.44
Bern Wankdorf Bern Wylersfeld	102.94
	0.39
	103.33
Lorraine Gl. 500 / 600	2.80
Bern	106.13

Höhen über Meer RPN = 373.60
 Längsprofil
 Grösste Steigung
 Grösstes Gefälle
 Stationen
 Abzweigungen
 Übergänge
 Grösste Ausweichweite

Blickstationen
 Bern JKL
 Bern
 Bern JKL
 Gleise P (J2,J7,J8)
 Gleise G (J1,M11)
 Entf. von Stat. zur Stat.
 Klammernung der Bahn



I-FN-FPA-RME

v. u. n. Zürich

09 Dez 2012 - 14 Dez 2013
(Vers 25)

00-12 Uhr

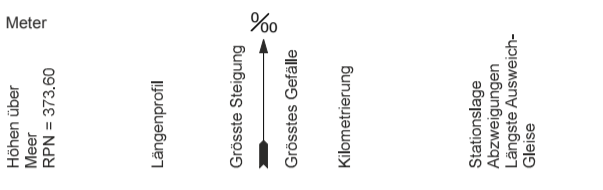
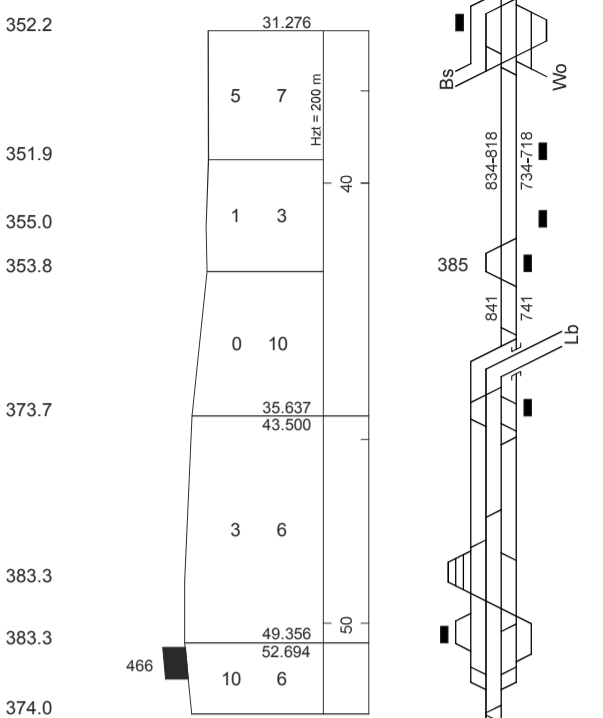

Station	Entf. von Stat. zu Stat.	Entf. vom Ausgangspunkt
BRUGG (AG)	4.87	12.23
Schinznach Bad	7.36	
Holderbank AG	2.61	4.75
Wildegg	1.66	3.09
Rapperswil	3.09	0.00 / 19.25
Rohr (Spw)	4.65	
AARAU (GB/PB)	1.20	14.60
Wöschnau (Spw)	1.53	13.40
		11.87

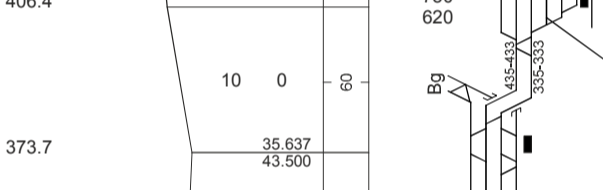
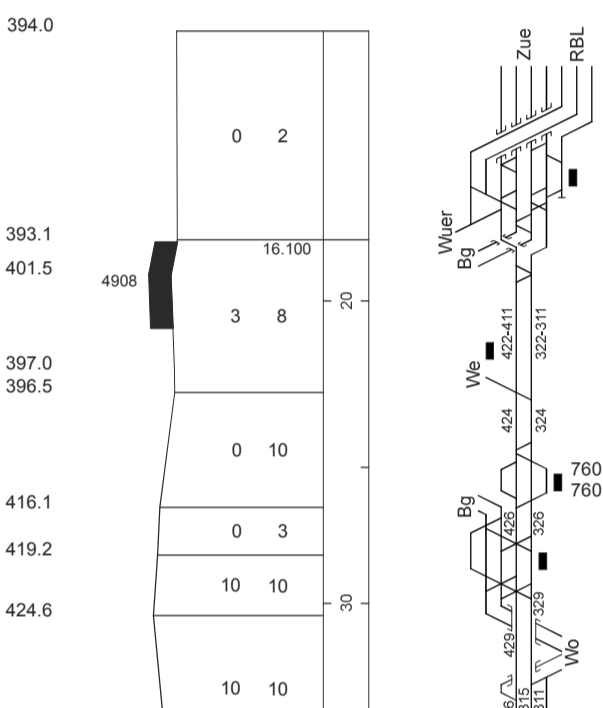

Station	Entf. von Stat. zu Stat.	Entf. vom Ausgangspunkt
RB Limmattal	3.88	
Killwangen-Spreitenbach	1.30	38.70 / 37.40
Mellingen Heitersberg v. u. n. Wettingen Gruemet (Abzw)	5.61	31.79
Mägenwil	2.90	28.89
Othmarsingen	1.77	27.12
Gexi	2.29	24.83
Lenzburg	1.98	22.85
v. u. n. Suhr	3.60	
Rapperswil	4.65	19.25
Rohr (Spw)	4.65	
AARAU (GB/PB)	1.20	14.60
Wöschnau (Spw)	1.53	13.40
Schönenwerd	3.03	11.87
Däniken	2.46	8.84
Dulliken	2.75	6.38
Olten Ost (Abzw)	3.63	3.63
Verbindungsline v. u. n. Basel	3.63	
OLTEN PB	0.00	0.00

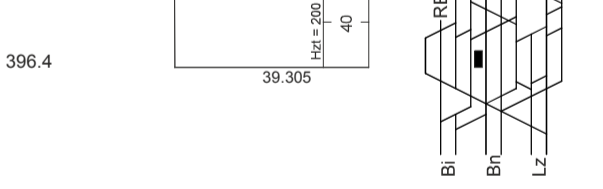
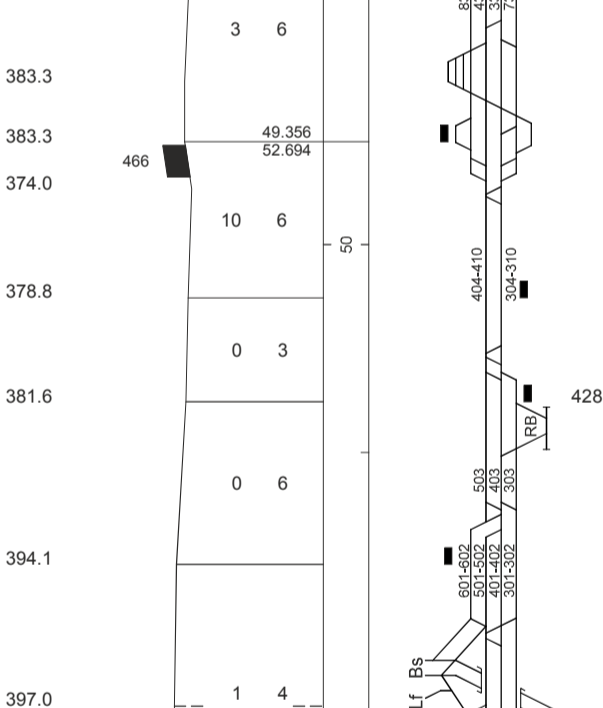

Station	Entf. von Stat. zu Stat.	Entf. vom Ausgangspunkt
Rapperswil	4.65	19.25
Rohr (Spw)	4.65	
AARAU (GB/PB)	1.20	14.60
Wöschnau (Spw)	1.53	13.40
Schönenwerd	3.03	11.87
Däniken	2.46	8.84
Dulliken	2.75	6.38
Olten Ost (Abzw)	3.63	3.63
Verbindungsline v. u. n. Basel	3.63	
OLTEN PB	0.00	0.00

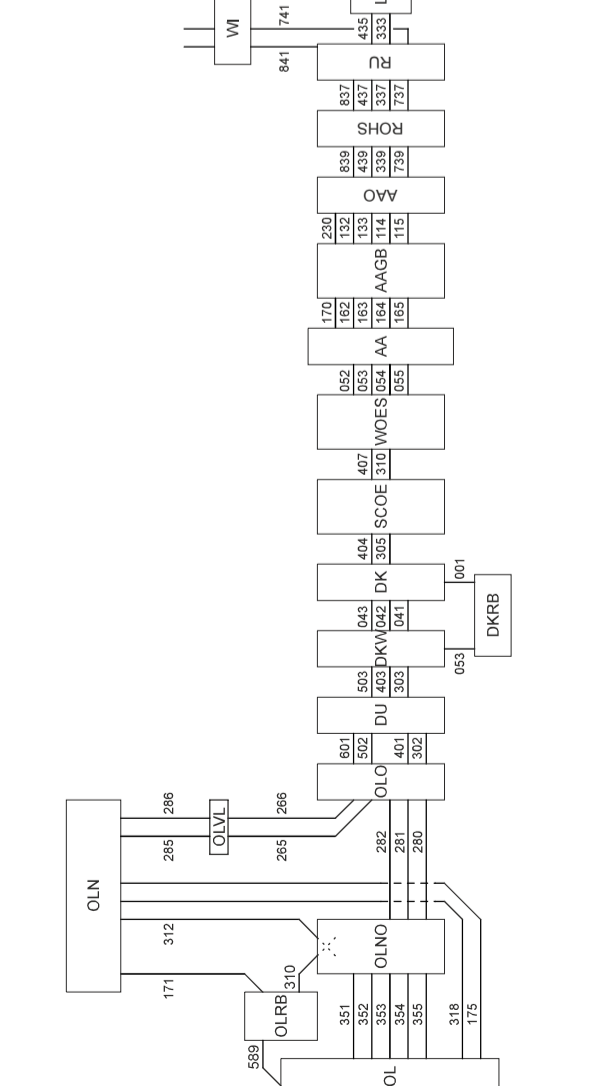

Station	Entf. von Stat. zu Stat.	Entf. vom Ausgangspunkt
v. u. n. Bern		
Dulliken		
Olten Ost (Abzw)		
v. u. n. Aarau		
v. u. n. Basel		
OLTEN (RB/PB)		
v. u. n. Biel/Bienne		
v. u. n. Aarau		
Däniken RB		
v. u. n. Olten		



SBB 16 A

I-FN-FPA-ROT

09 Dez 2012 - 14 Dez 2013 (Vers 25)

Mellingen Heitersberg
vln Lenzburg

0-6

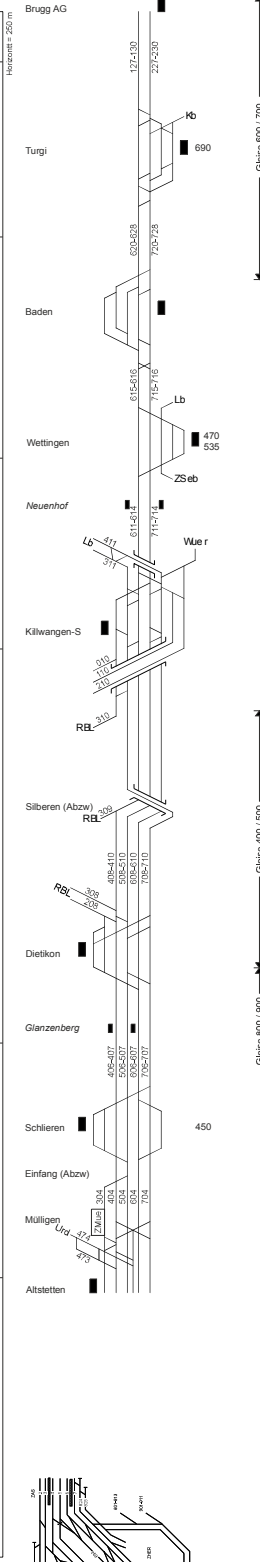
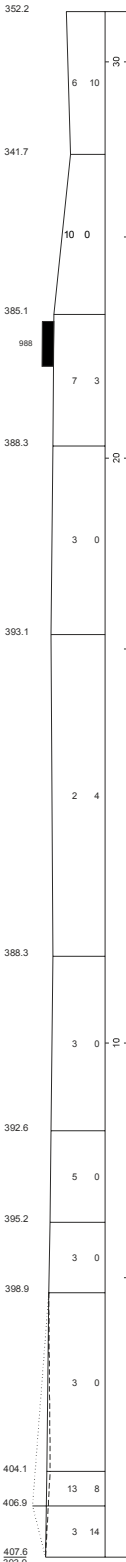

+	Langacher Killwangen-S	16.11
+	Dietikon	11.12
+	Glanzenberg	1.62 9.50
+	Schlieren	2.00 7.50
+	Z Altstetten	3.34 4.16
+	Z Hardbrücke West (Spw)	2.24
+	Z Hardbrücke 5+6	1.92
+	Z Langstrasse	1.92
+	Zürich PB A3-18	0.00

+	Brugg Nord vln Basel	
+	Brugg AG	31.27
+	vln Koblenz	3.84
+	Turgi	27.43
+		4.90
+	Baden	22.53
+		2.27
+	Wettingen vln Z Seebach	20.26
+	Neuenhof	1.50 18.76
+		2.65
+	Killwangen-S	16.11
+	Silberen (Abzw)	2.80 13.31
+	Dietikon	2.19 11.12
+	Glanzenberg	1.62 9.50
+	Schlieren	2.00 7.50
+	Einfang (Abzw)	1.19 6.31
+		2.15
+	Z Altstetten	4.16
+	Z Hardbrücke 1+4	2.24 1.92
+	Z Langstrasse	1.92
+	Zürich PB S21-24	0.00

+	Einfang (Abzw)	
+	Z Mülligen	0.65
+		0.94
+	Z Altstetten	
+	GI. 242/142	2.08
+	Zürich VB Zürich VB Nord	
+	GI. M 1-3	2.08
+	Zürich PB A3-18	
+	Z Altstetten	
+	GI. 215	1.37
+	Zürich VB West (Feld Z)	
+	Zürich VB	0.71
+	Z Altstetten	
+	GI. 694	2.08
+	Zürich VB Zürich VB Ost GI. 691/791	
+	Zürich PB A3-18 Q51-54	2.08

+	Urdorf vln Zug	4.41
+	Z Altstetten	2.35
+	Hard Käferberg (Abzw)	
+		3.08
+	Z Oerlikon	

Baden Oberstadt

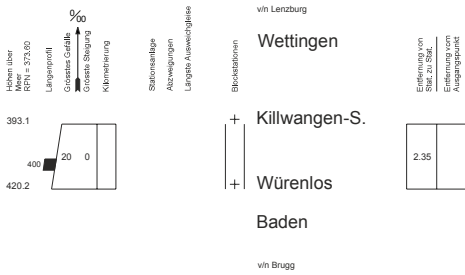

Killwangen-S.

Würenlos

Baden

v/n Brugg

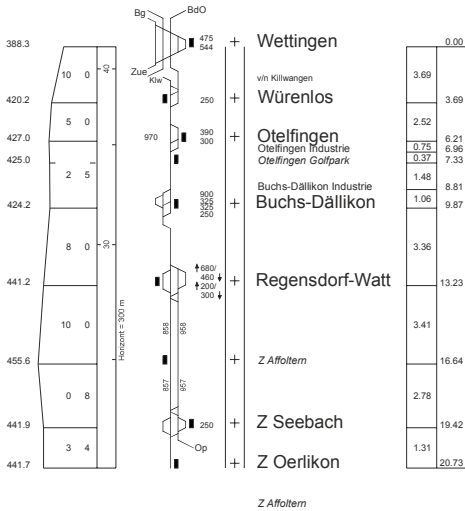

Wettingen

Würenlos

Otelfingen

Otelfingen Industrie
Otelfingen Golfpark

Buchs-Dällikon

Regensdorf-Watt

Z Affoltern

Z Seebach

Z Oerlikon

Z Affoltern

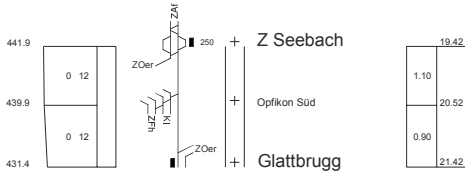

v/n Bülach

Tankanlage Rümlang

Opfikon Süd

Opfikon

v/n Kloten

Riet

Z Altstetten

Z Herdern

Z Hardbrücke

Z Langstrasse

Zürich PB S21-24

Z Herdern

Zürich VB Nord

Gl. M1-3

Zürich PB A3-18 Q51-54

Zürich VB Nord

Gl. 591

Zürich PB A3-18 Q51-54

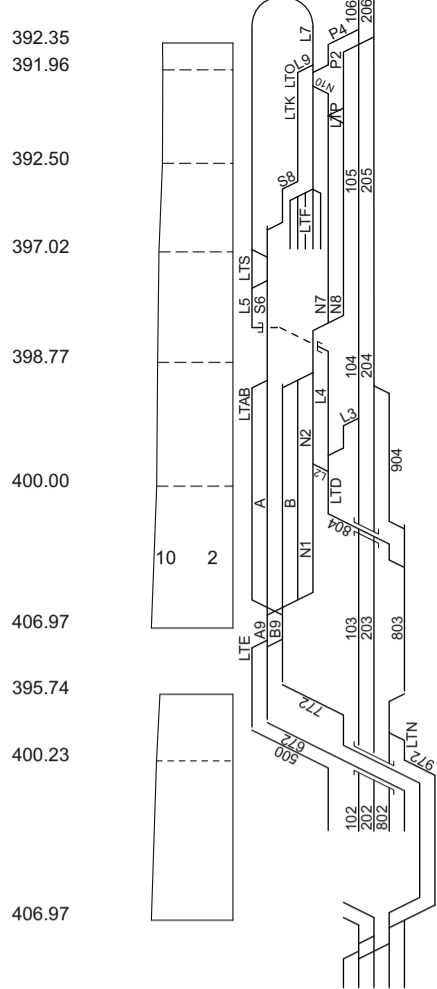

+	Lausanne-Triage F	9.30
+	Lausanne-Triage Ouest	0.51
+	Record Buchet	9.81
+	Praz Lebaz	1.67
+	Lausanne-Triage Sud	11.48
+	Bosse	1.37
+	Lausanne-Triage D	12.85
+		0.36
+	Lécheires (bif)	13.21
+		0.63
+	Lausanne-Triage Nord	13.84
+	voie 972	1.08
+	Bussigny	14.92
+	Lausanne-Triage A/B	8.10
+	Lausanne-Triage E	0.98
+		7.12
+		13.39
+	voie 772	1.53
+	Bussigny	14.92

d/p Vevey

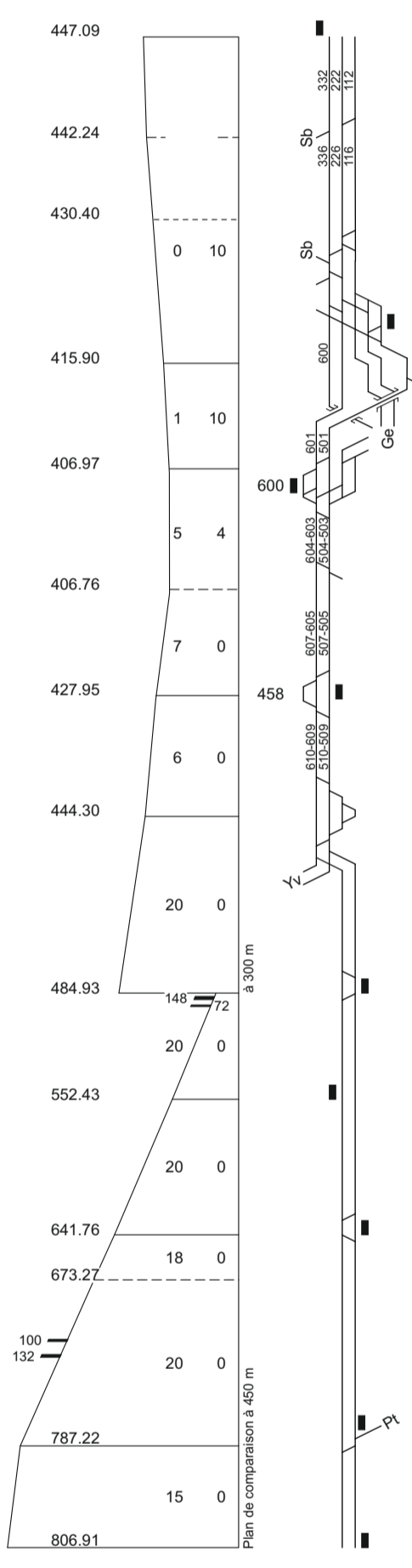

+	d/p Palézieux	
+	Lausanne	0.00
+		1.13
+	Lausanne (bif)	1.13
+		1.22
+	Prilly-Malley	2.35
+		1.40
+	Renens VD Est (bif)	3.75
+	Renens VD	0.76
+	Renens VD Ouest (bif)	4.51
+	d/p Genève (voies 201/101)	0.99
+	d/p Lausanne-Triage	1.43
+	Bussigny	6.93
+	Fallien	4.05
+	Vufflens-la-Ville	10.97
+	Gollion	3.51
+	Cossonay	14.49
+	Vaux	3.92
+	Dailens	18.41
+	d/p Yverdon-les-Bains	
+		4.34
+	La Sarraz	22.75
+		4.82
+	Arnex	27.56
+		6.14
+	Croy-Romainmôtier	33.70
+	Bretonnières	2.12
+		35.82
+		7.46
+	d/p Le Brassus	
+	Le Day	43.28
+		3.03
+	Vallorbe	46.31
+	Vallorbe-Frontière	461.60

Altitude au dessus de la mer
RFN = 373.60

Profil en long

Pente maximum
Rampe maximum

Situation des stations, bifurcations, plus longues voies d'évitement

Stations de block

Distance de stat. à stat.
Kilométrage de la voie

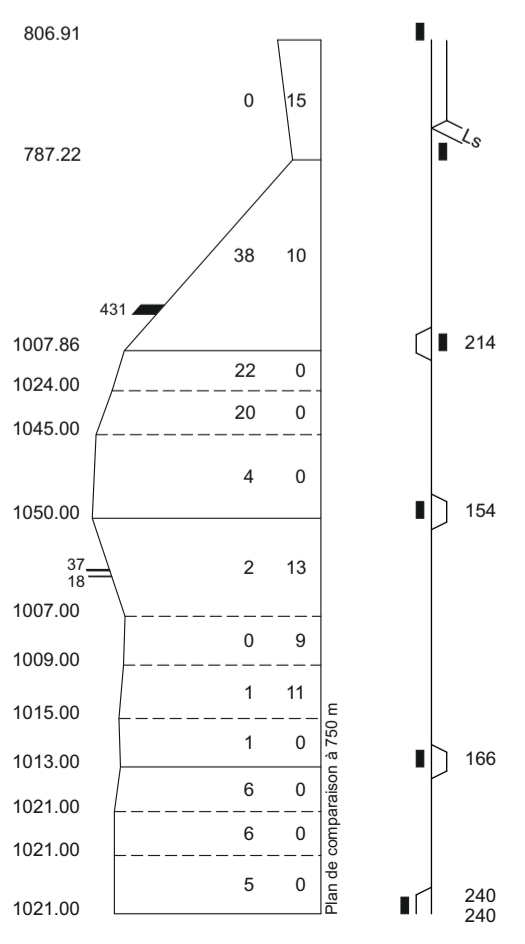

+	Vallorbe	46.31
+		0.00
+		3.03
+	Le Day	43.28
+	d/p Lausanne	3.03
+		8.60
+	Le Pont	11.63
+	Charbonnières	0.91
+	Séchéy	12.19
+		1.08
+	Le Lieu	13.27
+		2.19
+		15.45
+		2.45
+	Esserts-de-Rive	17.90
+	Le Rocheray	1.15
+		19.05
+	Solliat-Golisse	1.44
+	Sentier-Orient	20.50
+		1.15
+		21.65
+	Chez-le-Maître-Ecoles	1.07
+		22.72
+	Chez-le-Maître	0.28
+		23.00
+	Le Brassus	1.40
+		24.40

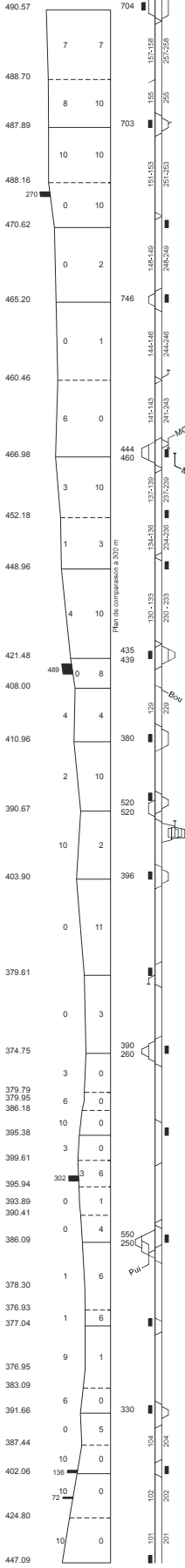

d/p Brig

+	Sion	92.43	
+	Châteauneuf-Conthey	4.36	
+	88.07		
+	2.76		
+	Ardon	85.31	
+	3.18		
+	Chamason	82.12	
+	2.55		
+	Riddes	79.57	
+	4.30		
+	Saxon	75.27	
+	4.41		
+	Charrat-Fully	70.86	
+	4.37		
+	d/p Orsières		
+	Martigny	66.50	
+	d/p Le Châtelard-Frontière		
+	4.99		
+	Vernayaz	61.51	
+	3.65		
+	Evionnaz	57.85	
+	6.29		
+	St-Maurice	51.56	
+	1.50		
+	Les Paluds	50.07	
+	d/p Bouveret		
+	2.51		
+	Bex	47.56	
+	d/p Villars		
+	3.96		
+	St-Triphon	43.60	
+	4.29		
+	d/p Champéry		
+	Aigle	39.31	
+	d/p Laysin (2.)		
+	d/p Les Diablerets (4.)		
+	5.47		
+	Roche VD	33.84	
+	4.50		
+	Villeneuve	29.34	
+	2.25		
+	Veytaux-Chillon	27.09	
+	Veytaux	1.07	
+	Terriet	26.02	
+	d/p Montbovon		
+	Montreux	1.48	
+	d/p Caux		
+	Clarens	1.44	
+	23.10		
+	1.57		
+	Burier	21.53	
+	Tour-de-Peilz	1.62	
+	La Tour-de-Peilz	19.90	
+	d/p Blonay		
+	Vevey	1.50	
+	d/p Puidoux-Chexbres		
+	18.40		
+	17.64		
+	17.66		
+	3.87		
+	Roseville		
+	St-Saphorin	14.55	
+	Rivaz	1.00	
+	13.55		
+	Dézaley	3.57	
+	Epeses	9.98	
+	Cully	1.45	
+	8.52		
+	Villette VD	1.84	
+	6.68		
+	Lutry	1.61	
+	5.07		
+	2.57		
+	Pully	2.51	
+	2.51		
+	Lausanne	0.00	

Altitude au dessus de la mer = 373.60
RPN = 373.60

Profil en brig

Pente maximum

Rampes maximum

Situations des stations bleues, cationes, plus longues cotes d'écrêtement

Stations de bloc

d/p Palézieux

Lausanne

Châtaignier de la voie

Kilométrage de la voie

d/p Renens

Altitudine sul
livello del mare
S.M. = 373,00

Profilo in lungo
Pendenza massima
Rampa massima

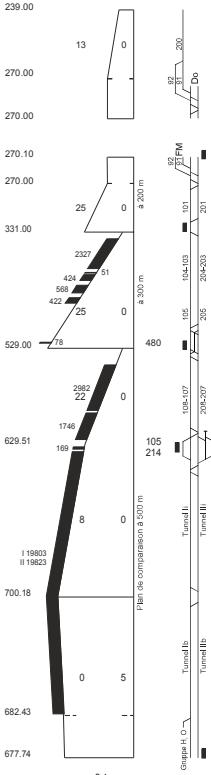

Höhen über
RPN = 373,00

Längsprofil
Grösste Steigung
Grösstes Gefälle

Stationsbezugs
Abzweigungen,
Längste Ausweich-
gleise

Altitude au dessus
RPN = 373,00

Profil en long
Pente maximum
Rampe maximum

Situation des
stations, bifur-
cations, plus
longue déviation
d'écartement

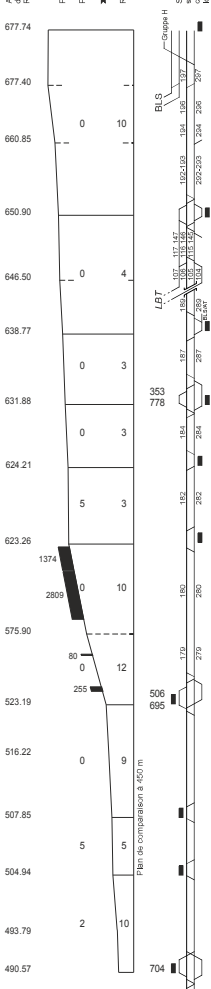

Altitude au dessus
RPN = 373,00

Profil en long
Pente maximum
Rampe maximum

Situation des
stations, bifur-
cations, plus
longue déviation
d'écartement

d/p Milano

d/p Locarno

Stazioni di Mocco

v/in Furka

v/in Zermatt

v/in Thun

d/p St-Maurice

Domodossola			
Domodossola II			
Domodossola FM	1.08	5.23	5.23
Domodossola (bif)	6.31	1.24	1.24
Domodossola			
Domodossola (bif)	1.24	1.24	0.00
Preglia	2.59	3.83	3.83
Rio Rido			
Mognatta	8.72		
Varzo			
Galleria elicoidale	6.25		
Iselle di Trasquera	18.80	167.48	167.48
	11.13		
Staz. della Galleria Sempione	156.35		
	9.20		
Brig Tunnel	147.15		
Brig	1.60	145.55	145.55

Brig (Bahnhofplatz)			
---------------------	--	--	--

Brig			
------	--	--	--

Brig			
Brig Lötschberg (Abzw)	0.30	145.25	145.25
Gliser Grund	3.81		
Gamsen SBB	141.44		
Visp	4.71		
v/in Zermatt	3.45		
St. German (Abzw)	133.28	50.06	50.06
	3.19		
Raron	130.09		
Gampel-Steg	4.22		
Turtmann	3.75		
Leuk	4.49	118.83	118.80
	5.33		
Salgesch	112.25		
Sierre/Siders	4.12		
Noës	6.57		
Granges-Lens	101.56		
St-Léonard	3.40		
Clavoz	5.72		
Sion	92.43		

Presenza da stazione
a stazione
Chilometraggio
del binario

Entrée von
Staz. zu Staz.
Kilometrierung
der Bahn

Présence de
staz. à staz.
Kilométrage
de la voie

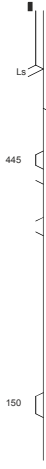
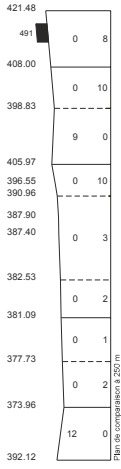

d/p Sion

+	St-Maurice	51.56
+	Les Paluds d/p Lausanne	1.50 50.07 1.47
+	Massongex	1.73 3.20
+	Monthey	2.85 6.05
+	Monthey Giovanola (embr)	1.16 7.21
+	Collombey	0.70 7.91
+	Monthey centre agr Bas-Valais (embr)	1.18 9.09
+	Monthey AGIP (embr)	1.00 10.09
+	Vionnaz	3.30 13.39
+	Vouvry	2.87 16.25
+	Les Evouettes	3.27 19.53
+	Bouveret	3.39 22.91
+	St-Gingolph (Suisse)	3.89 26.80

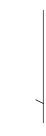
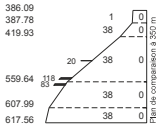

d/p Lausanne

Vevey

d/p Sion

+	Vevey	0.00
+	Vevey-Funi	0.85
+	Corseaux-Cornalles	0.90 1.75
+	Chexbres-Village	3.86 5.61
+	Le Verney (embr)	1.49 7.10
+	Puidoux-Chexbres	0.73 7.83

Altitude au dessus
de la mer
RPN = 373.00

Profil en long

Pente maximum
Rampes maximum

Situations des
stations, bifur-
cations, plus
longues voies
d'entretien

Stations de
travail

d/p Lausanne

Puidoux-Chexbres

Changement de
niveau à cet
endroit

Changement de
niveau de la voie

d/p Palézieux

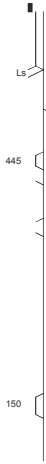
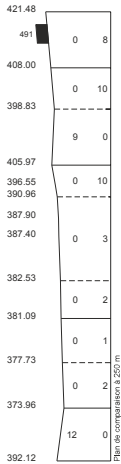

d/p Sion

+	St-Maurice	51.56
+	Les Paluds d/p Lausanne	1.50 50.07 1.47
+	Massongex	1.73 3.20
+	Monthey	2.85 6.05
+	Monthey Giovanola (embr)	1.16 7.21
+	Collombey	0.70 7.91
+	Monthey centre agr Bas-Valais (embr)	1.18 9.09
+	Monthey AGIP (embr)	1.00 10.09
+	Vionnaz	3.30 13.39
+	Vouvry	2.87 16.25
+	Les Evouettes	3.27 19.53
+	Bouveret	3.39 22.91
+	St-Gingolph (Suisse)	3.89 26.80

d/p Lausanne

Vevey

d/p Sion

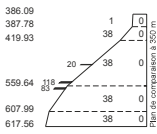

d/p Lausanne

+	Vevey	0.00
+	Vevey-Funi	0.85
+	Corseaux-Cornalles	0.90 1.75
+	Chexbres-Village	3.86 5.61
+	Le Verney (embr)	1.49 7.10
+	Puidoux-Chexbres	0.73 7.83

Stations de
travail

d/p Lausanne

Puidoux-Chexbres

Changement de
niveau à cet
endroit

Changement de
niveau de la voie

d/p Palézieux

24 A

0-6

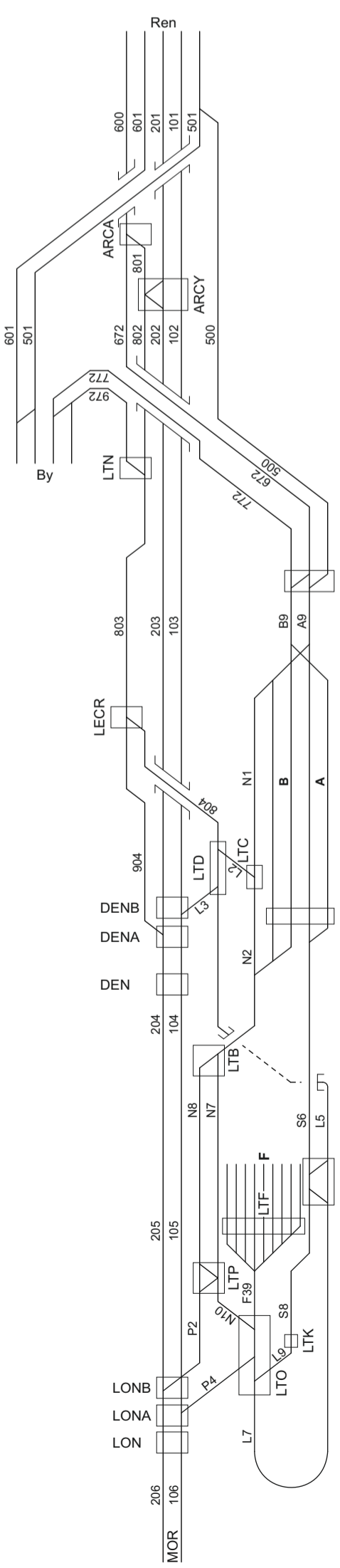
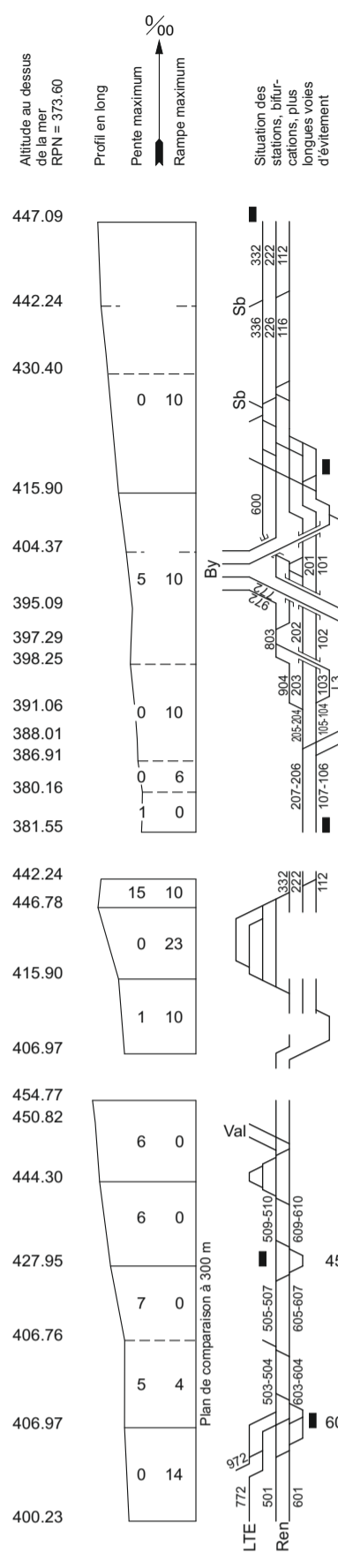

Stations de block	Distance de stat. à stat.	Kilométrage de la voie
Lausanne		0.00
Lausanne (bif)	1.13	1.13
Prilly-Malley	1.22	2.35
Renens VD Est (bif)	1.41	3.76
Renens VD	0.75	4.51
Renens VD Ouest (bif)	0.99	5.50
d/p Dailiens	0.81	6.31
Archy (bif)	1.72	8.03
Venoge	0.24	8.27
Denges B (bif)	0.11	8.38
Denges A (bif)	1.33	9.71
Denges-Echandens	0.29	10.00
Denges Lonay B (bif)	0.12	10.12
Lonay A (bif)	1.04	11.16
Lonay-Préverenges	1.34	12.50
Morges-St-Jean		
Morges		
Lausanne (bif)	0.39	1.13
Lausanne-Sébeillon	2.24	1.52
Renens VD Est (bif)	0.75	3.76
Renens VD	0.99	4.51
Renens VD Ouest (bif)	1.43	5.50
Bussigny		6.93
Eclépens		21.38
Eclépens sud	0.79	20.59
d/p Vallorbe	2.18	
Dailiens		18.41
Vaux	3.92	
Cossonay		14.49
Gollion	3.51	
Vufflens-la-Ville	4.05	10.97
Fallien		
Bussigny		6.93
d/p LTN voie 972		14.92
voie 772	1.53	
Lausanne-Triage Est		13.39
Renens VD		4.51
Renens VD Ouest (bif)	voie 500	0.99
Lausanne-Triage Est		1.62
7.12		
Renens VD		4.51
Renens VD Ouest (bif)	voie 600	0.99
Archy A (bif)		0.41
5.50		
5.91		
voie 672		1.35
Lausanne-Triage Est		7.26
voies A9/B9		0.98
7.12		
Lausanne-Triage A/B		8.10
Lausanne-Triage B		0.40
8.50		
Lausanne-Triage Est		7.12
voie N1		0.84
Lausanne-Triage C		7.96
voie N2		0.54
Lausanne-Triage B		8.50
voie N7/8		0.91
Lausanne-Triage P1		9.41
Lausanne-Triage Ouest	voie N10	0.31
Lonay A (bif)	voie P4	0.30
9.72		
9.76		
10.00		
Lausanne-Triage A/B		8.10
voie S6		0.84
9.38		
Lausanne-Triage Sud		8.94
11.59		
voie P4		0.70
Lausanne-Triage K		10.89
voie L9		0.24
Lausanne-Triage Ouest		10.65
Lausanne-Triage P1		9.40
voie P2		0.30
Lonay B (bif)		9.70
Bussigny		14.92
voie 972		1.08
Lausanne-Triage Nord		13.84
Lausanne-Triage C		7.96
voie L2		0.26
Lausanne-Triage D		7.70
7.72		
voie L3		0.31
Denges B (bif)		8.03
Denges A (bif)		8.27
voie 904		0.91
Lécheires (bif)		7.36
Renens VD		4.51
Renens VD Ouest (bif)	voie 600	0.99
Archy A (bif)		0.41
5.50		
5.91		
Archy (bif)	voie 801	0.22
6.12		
Lausanne-Triage Nord	voie 802	0.62
6.75		
13.84		
voie 803		0.63
Lécheires (bif)		13.21
Lausanne-Triage D	voie 804	0.36
Bosse		12.85
Lausanne-Triage Sud	voie L4	1.37
11.48		
Praz Lebaz		
voie L7		1.67
Record Buchet		
Lausanne-Triage Ouest		9.81
Lausanne-Triage F		0.51
9.72		

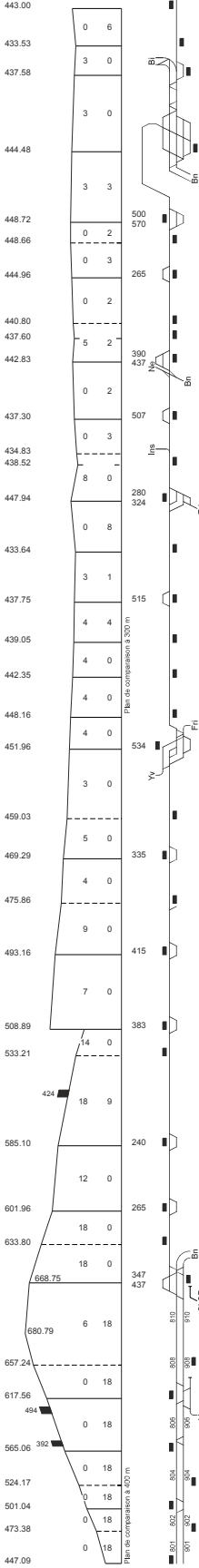

- + Büren an der Aare
- Dotzigen
- v/h Biel/Bienne
- Busswil
- Lyss
- v/h Bern
- Aarberg
- Bargen
- Kallnach
- Fräschels
- Kerzers Papilorama
- v/h Neuchâtel
- Kerzers
- v/h Bern
- Galmiz
- v/h Ins
- Muntelier
- Muntelier-Löwenberg
- Murten
- d/p Fribourg
- Faoug
- Avenches
- Domdidier
- Dompierre
- Corcelles-Nord
- d/p Fribourg
- Payerne
- d/p Yverdon-les-Bains
- Trey
- Granges-Marnand
- Henniez
- Lucens
- Moudon
- Bressonaz
- Ecublens-Rue
- Châtillens
- Palézieux-Village
- d/p Bern
- Palézieux
- d/p Châtel-St-Denis
- Corbéran
- Moreillon
- Puidoux-Chexbres
- d/p Vevey
- Grandvaux
- Bossière
- La Conversion
- Pully-Nord
- Lausanne

3.48	95.71
99.19	
2.67	101.86
26.16	
2.79	
23.37	
23.60	
100.42	
5.16	
95.49	
1.56	
93.94	
2.57	
91.37	
3.70	
87.67	
1.17	
87.69	
86.52	
1.71	
84.81	
4.14	
80.67	
1.58	
79.09	
0.52	
78.57	
2.05	
76.52	
3.72	
72.80	
3.69	
69.12	
2.93	
66.19	
2.53	
63.66	
2.90	
60.76	
2.34	
59.45	
59.50	
58.47	
5.06	
53.41	
2.96	
50.44	
3.26	
47.18	
3.80	
43.38	
5.41	
37.98	
1.91	
36.07	
5.45	
30.61	
4.72	
25.89	
2.48	
23.41	
2.81	
20.60	
5.98	
14.62	
2.46	
12.16	
3.85	
8.31	
2.53	
5.78	
1.77	
4.00	
1.64	
2.37	
2.37	
0.00	

Altitude au dessus
de la mer
PNM = 375.00

Profil en long

Pente maximum
Rampe maximum

Situation des
stations, plus
ou moins
d'alignement

Stations de block

d/p Vevey

Lausanne

d/p Renens

Distance de
sûreté à l'arrêt.

Relevé de
la voie

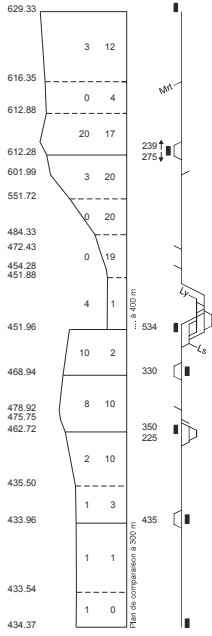

Altitudes au-dessus
de la mer
RN = 373.00

Profil en long

Pente maximum
↑
Rampes maximum

Stations des
stations, bifur-
cations, pla-
teaux, plaques
longues voies
d'évitement

d/p Lausanne

Fribourg

d/p Bern

Fribourg	49.92
+	
+	4.00
Givisiez	45.92
d/p Murten	1.47
Belfaux CFF	44.45
	4.33
Grolley	40.12
Léchelles Tanklager (embr)	2.09
Léchelles	38.03
	2.55
	35.48
	3.71
Cousset	31.77
Bossy Moulins (embr)	0.73
	31.04
Bossy Bois (embr)	1.05
Corcilles-Sud	29.99
	0.26
	29.73
d/p Lyss	1.84
Payerne	27.89
d/p Lausanne	4.21
Cugy FR	23.68
	3.65
Sévaz (embr)	20.03
Siporex (embr)	0.56
Estavayer-le-Lac	19.47
	1.40
	18.07
Cheyres	5.45
	12.62
Yvonand	3.81
	8.81
	7.03
Yverdon-Champ Pittet	1.78
	0.00
Yverdon-les-Bains	39.13

d/p Lausanne

Yverdon-les-Bains

d/p Neuchâtel

Stations de bloc

Distances de
côté à côté

Kilométrage
de la voie

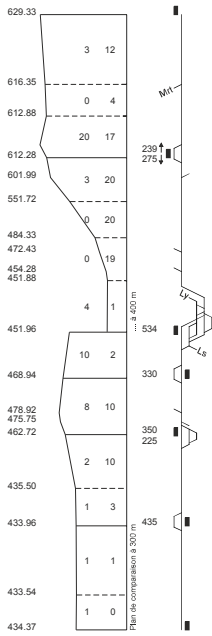

Altitudes au-dessus
de la mer
RN = 373.00

Profil en long

Pente maximum
↑
Rampes maximum

Stations des
stations, bifur-
cations, pla-
teaux, plaques
longues voies
d'évitement

d/p Lausanne

Fribourg

d/p Bern

Fribourg	49.92
+	
+	4.00
Givisiez	45.92
d/p Murten	1.47
Belfaux CFF	44.45
	4.33
Grolley	40.12
Léchelles Tanklager (embr)	2.09
Léchelles	38.03
	2.55
	35.48
	3.71
Cousset	31.77
Bossy Moulins (embr)	0.73
	31.04
Bossy Bois (embr)	1.05
Corcilles-Sud	29.99
	0.26
	29.73
d/p Lyss	1.84
Payerne	27.89
d/p Lausanne	4.21
Cugy FR	23.68
	3.65
Sévaz (embr)	20.03
Siporex (embr)	0.56
Estavayer-le-Lac	19.47
	1.40
	18.07
Cheyres	5.45
	12.62
Yvonand	3.81
	8.81
	7.03
Yverdon-Champ Pittet	1.78
	0.00
Yverdon-les-Bains	39.13

d/p Lausanne

Yverdon-les-Bains

d/p Neuchâtel

Stations de bloc

Distances de
côté à côté

Kilométrage
de la voie

Altitude au dessus de la mer
RPN = 373.60

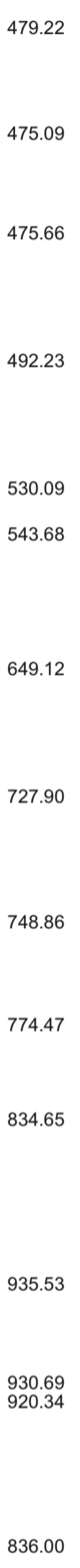

Profil en long

Pente maximum
Rampe maximum

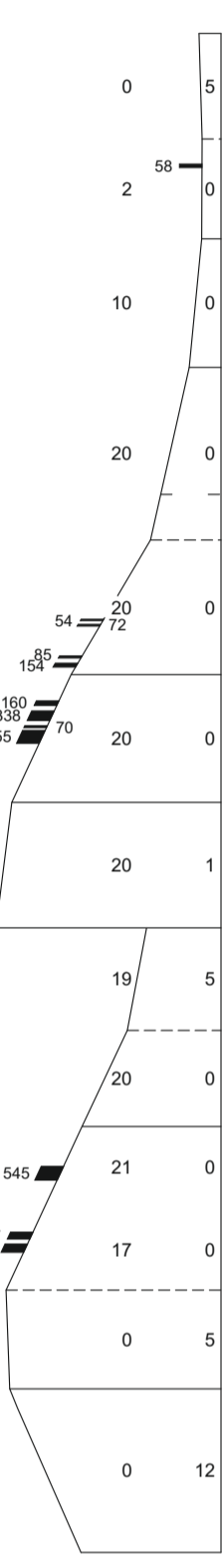

Situation des stations, bifurcations, plus longues voies d'évitement



Stations de block

Station	Distance de stat. à stat.	Kilométrage de la voie
Bern		
Kerzers		
Ins		
Neuchâtel		
d/p Biel/Bienne		
Neuchâtel		75.29
Neuchâtel-Vauseyon (bif) d/p La Chaux-de-Fonds	1.34	73.96
Neuchâtel-Serrières	1.57	72.39
	2.05	
Auvernier d/p Lausanne	2.71	70.34 4.98
Cottendart (embr)		7.69
Bôle	0.61	8.30
	5.35	
Champ-du-Moulin	4.46	13.65
	4.46	
Noiraigue		18.11
	4.34	
Travers d/p Buttes	3.60	22.45
Couvet CFF		26.04
	3.43	
Boveresse		29.47
	6.43	
Les Bayards		35.90
	3.46	
Les Verrières Les Verrières-Frontière	1.71	39.36 41.07
	11.28	
Pontarlier		52.35 SNCF 453.56



Profil en long

Pente maximum
Rampe maximum

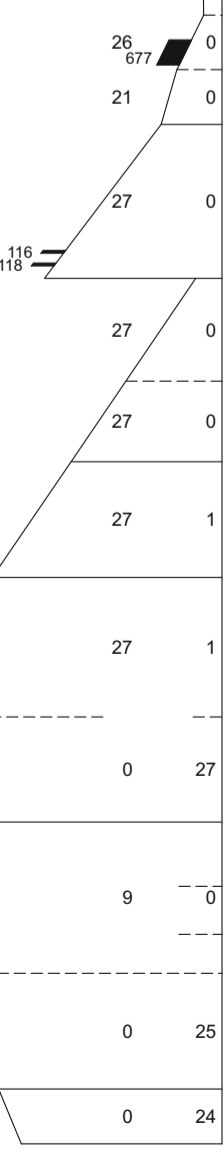

Situation des stations, bifurcations, plus longues voies d'évitement

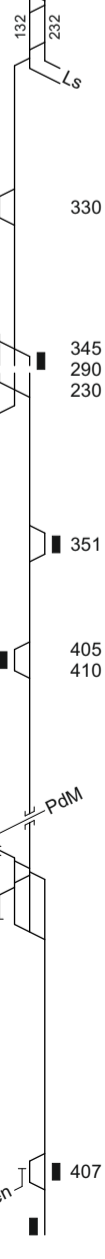

Stations de block

Station	Distance de stat. à stat.	Kilométrage de la voie
Neuchâtel faisceau D		
Neuchâtel		75.29
Neuchâtel-Vauseyon (bif) d/p Lausanne/Travers Neuchâtel-Vauseyon	1.34 1.37	73.96 1.64
Les Deurres	1.46	3.10
Corcelles-Peseux	1.22	4.32
	6.08	
Chambrelieu		10.40
	3.66	
Montmollin-Montezillon		14.06
Les Geneveys-sur-Coffrane	2.84	16.90
	4.09	
Les Hauts-Geneveys		20.99
	8.51	
d/p Sonceboz		
La Chaux-de-Fonds d/p Saig ↙ d/p PdM ↘		29.49
La Chaux-de-Fonds-Ouest	1.15	30.64
Les Eplatures	1.54	32.18
Le Crêt-du-Loche	1.22	33.40
	3.67	
Le Locle d/p Les Brenets		37.07
Le Locle-Col-des-Roches Le Locle-Frontière	1.79	38.86 SNCF 481.737

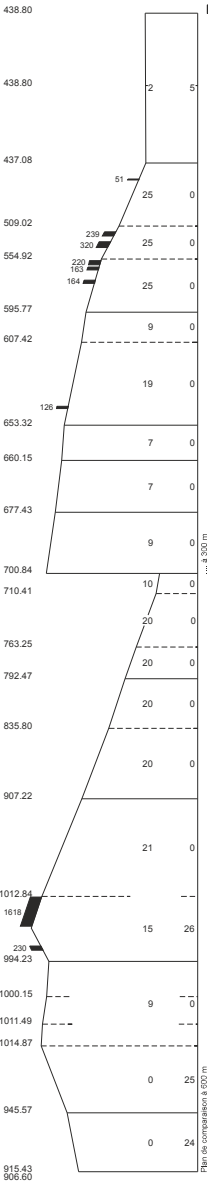

win Bern

Biel/Bienne

win Lengnau

Biel RB

Biel RB West

Biel/Bienne

Mahlenwald

Frinvillier-Taubenloch

Reuchenette-Péry

La Heutte

Sonceboz-Sombeval

Cortébert

Courtelary

Cormoret

Villeret

St-Imier

Sorvillier

Renan BE

La Chaux-de-Fonds

La Chaux-de-Fonds-Ouest

Les Eplatures

Le Crêt-du-Loche

Le Locle

Le Locle-Col-des-Roches

96.60
0.76
97.36
2.01
99.37
33.83
3.44
37.27
1.84
39.11
2.93
42.04
1.65
43.68
4.60
48.28
1.93
50.22
2.90
53.12
3.35
56.47
1.17
57.64
2.99
60.63
1.75
62.38
2.78
65.16
65.17
3.85
69.02
8.81
77.83
29.49
1.15
30.64
1.54
32.18
1.22
33.40
3.67
37.07
1.79
38.86
SNCF 481.737

Altitude au-dessus
de la mer en mètres
RPN = 973.60

Profil en long

Pente maximum

Rampe maximum

Stations des
stations, plus
lingues, plus
d'orientation

Stations de bloc

d/p Biel/Bienne

Distances de
dans le cas

Kilométrage
de la voie

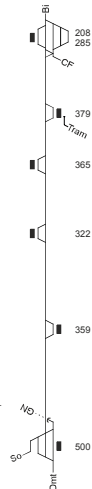
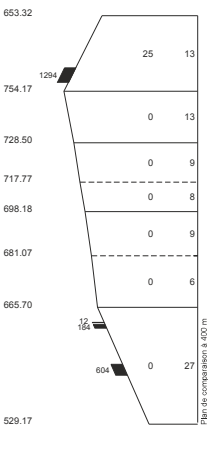

Sonceboz-Sombeval

Tavannes

Reconvieler

Pontenet

Malleray-Bévilard

Sorvillier

Court

Moutier

Moutier

Moutier

Moutier

Moutier

Moutier

Moutier

Moutier

Moutier

48.28
6.89
55.17
2.84
58.02
2.10
60.12
1.67
61.79
2.41
64.20
2.84
67.04
6.35
73.40

d/p Delémont



Couleur des
stations balis-
cations, plus
longues voies
d'évitement

vin Neuchâtel

vin Sonceboz

Biel/Bienne

vin Bern

Biel/Bienne

Biel RB West

Biel RB

Madretsch

Biel RB West

Biel RB

Biel Mett (Abzw)

Biel/Bienne

Biel Mett (Abzw)

Bann

Pieterlen

Lengnau

vin Solothurn

Grenchen Nord

Tunnelblock (Grenchenberg)

d/p Sonceboz

Moutier

d/p Solothurn

Choindez

Delémont

vin Basel

Laufen

Bärschwil

Liesberg

Soyhières

Delémont

Delémont

Courtételle

Courfaivre

Bassecourt

Glovelier

d/p Saignelégier

St-Ursanne

Courgenay

d/p Bonfol

Porrentruy

Courchavon

Courtemaîche

d/p Bure

Grandgourt

Buix

Boncourt

Delle-Frontière

Delle

Courtemaîche

Bure-Casernes

Distance de
l'axe à l'axe
Kilométrage
de la voie

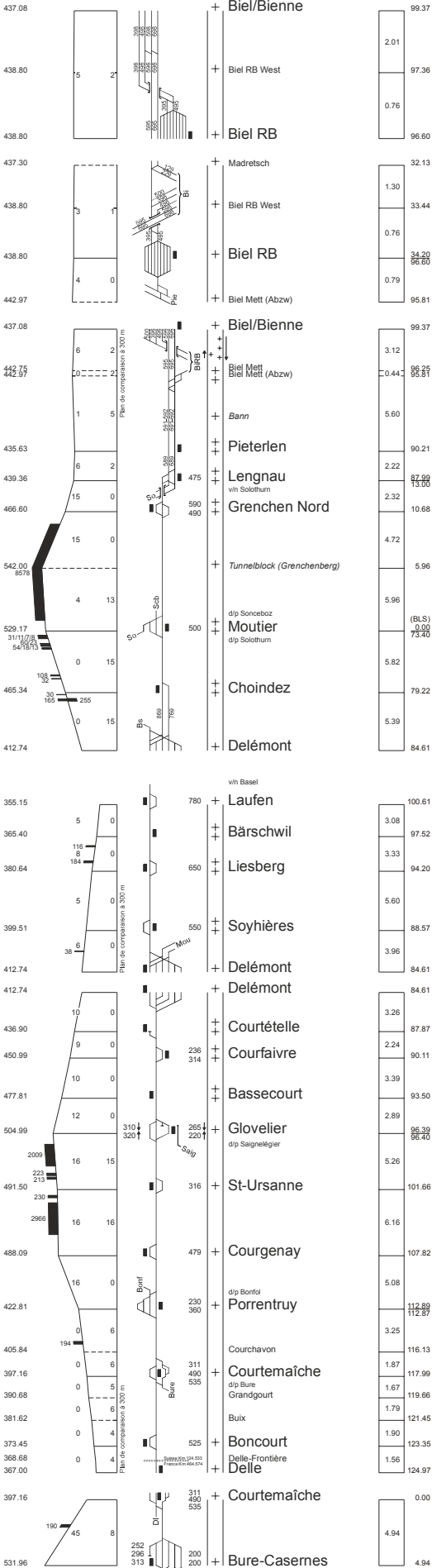

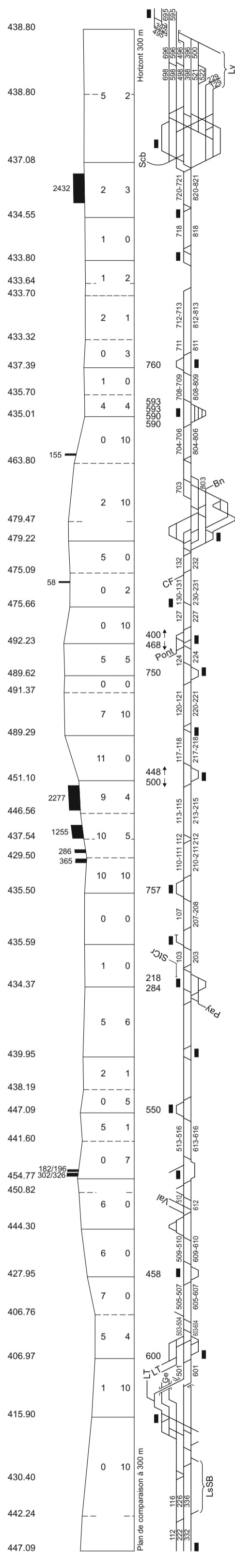

Altitude au dessus de la mer RPN = 373.60
Profil en long
Rampe maximum
Pente maximum
Situation des stations, bifurcations, plus longues voies d'évitement

Neuchâtel-Mail	76.14
Neuchâtel faisceau D	0.55
Neuchâtel	75.58
d/p Lengnau	0.29
Biel/Bienne	
Biel RB	96.60
Biel RB West	0.76
Biel/Bienne	99.37
d/p Sonceboz	104.50
Vingelz	4.55
Tüscherz	99.95
Twann	3.97
Ligerz	1.97
Chavannes	0.27
Poudeille	3.68
La Neuveville	90.05
Le Landeron	2.33
Cressier NE	2.17
Cornaux	1.95
Souaillon	4.23
St-Blaise CFF	79.37
La Coudre	3.23
Neuchâtel-Mail	76.14
Neuchâtel	0.85
Neuchâtel-Vauseyon (bif)	1.34
d/p La Chaux-de-Fonds	73.96
Neuchâtel-Serrières	1.57
Auvernier	2.05
d/p Pontarlier/Buttes	70.34
Colombier	2.67
Boudry	1.42
Perreux	66.25
Bevaix	3.97
Chassagne	62.28
Gorgier-St-Aubin	4.18
Vaumarcus	58.10
La Lance (diag é)	57.89
Concise	3.04
Onnens-Bonvillars	2.41
Grandson	1.69
d/p Ste-Croix	50.75
Yverdon-les-Bains	3.27
d/p Payerne	47.48
Champs-Lovats	4.77
Ependes	4.21
Essert-Pittet	3.58
d/p Orbe	42.71
Chavornay	3.58
Bavois	3.03
Eclépens	2.97
Eclépens sud	2.22
d/p Vallorbe	27.46
Daillens	2.58
Vaux	24.88
Cossonay	3.50
Gollion	3.50
Vufflens-la-Ville	21.38
Faillen	0.79
Bussigny	20.59
d/p Lausanne-Triage	2.18
d/p Genève	18.41
Renens VD Ouest (bif)	3.92
Renens VD	14.49
Renens VD Est (bif)	3.51
Prilly-Malley	10.97
Lausanne (bif)	4.05
Lausanne	6.93
d/p Palézieux	1.43
d/p Vevey	5.50
Ls-Triage C	0.99
Ls-Triage B	0.76
Ls-Triage Est	4.51
Ls-Triage A/B	1.40
Ls-Triage B	1.22
Ls-Triage Sud	2.35
Ls-Triage Ouest	1.13
Ls-Triage F	1.13

Stations de block
d/p Vevey
Ls-Triage C
Ls-Triage B
Ls-Triage Est
voie N2
voie A9/B9
Distance de stat. à stat.
Kilométrage de la voie



I-FN-FPA-RME

09 Dez 2012 - 14 Dez 2013
(Vers 25)

00-12 Uhr

v. u. n. Basel

OLTEN PB

v. u. n. Luzern/Bern via ABO
v. u. n. Aarau

Größe
351
352

Station	Abstand (km)
OLTEN PB	37.30
Rothrist	5.86
Wanzwil (Abzw)	19.39
Inkwil (Verzw)	12.05
Subingen	6.56
Derendingen	2.45
SOLOTHURN	3.04
	0.00

v. u. n. Aarau
v. u. n. Basel

OLTEN

Station	Abstand (km)
Olten Hammer	60.07
Wangen bei Olten	58.74
Hägendorf	2.42
Härkingen Paketpost	2.26
Egerkingen	2.14
Oberbuchsiten	1.66
Oensingen	2.32
Niederbipp	5.21
Wangen a.d. Aare	1.98
Deitingen	5.69
Luterbach-Attisholz	3.30
SOLOTHURN	2.75
Solothurn West	3.46
Bellach	0.96
Selzach	2.88
Grenchen Süd	3.04
Lengnau	2.19
Pieterlen	2.39
Bann	2.72
Biel Mett (Abzw)	2.22
BIEL PB	1.98
	3.61
	0.44
	3.12
	0.00

v. u. n. Neuchâtel

Biel Mett Abzw.

BIEL RB

v. u. n. Wiedlisbach

SOLOTHURN

v. u. n. Zollikofen

v. u. n. Bern

BIEL PB

Km
Entf. von
Stütz. zu Stütz.
Entf. vom
Ausgangspunkt

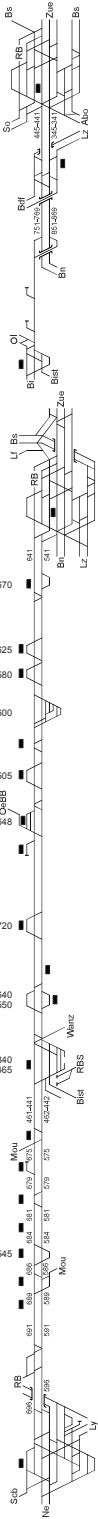
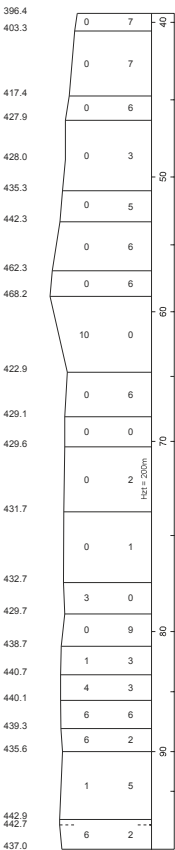

Meter

Höhen über
Meer
RFN=573.60
Längensprofil

Grösste Steigung
Grösste Gefälle

Kilometer

Stationen
Abzweigungen
Längste Ausweich-
Gleise

Blockstationen
bzw. Blockstellen

Km
Entf. von
Stütz. zu Stütz.

Km
Entf. vom
Ausgangspunkt

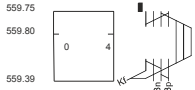

Thun Schadau (Abzw)		
+	Thun	137.02
	Thun Gruppe B	0.29 136.73
	Thun (Abzw)	0.58 136.15

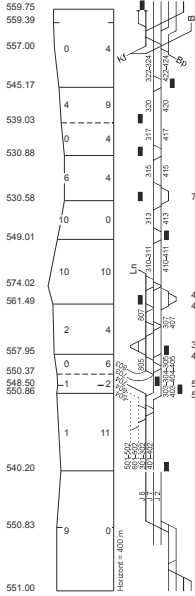

+	Thun	137.02
	Thun (Abzw)	0.87 136.15
	Lerchenfeld	1.52 134.63
	Allmend	3.53 131.10
	Uttigen	2.79 128.30
	Kiesen	2.57 125.73
	Wichtrach	3.60 122.13
	Münsingen	3.09 119.04
	Rubigen	3.67 115.37
	Allmendingen	1.41 113.96
	vin Langensud	
	Gümligen (Abzw)	
	Gümligen	3.19 110.77
	Dennigkofen	1.28 109.48
	Ostermundigen	0.51 108.97
	Wankdorf (Abzw)	0.30 108.58
	Bern Wankdorf	0.30 108.58
	Bern Wylerfeld	0.30 103.33
	Lorraine	Gl. 300 / 400 2.80
	Bern	106.16 97.10
	Bern JKL M	0.78 96.32
	Bern Weyermannshaus	1.32 95.00

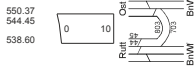

+	Wankdorf (Abzw)	103.17
	Lochligut Süd (Abzw)	0.67 102.50
	Lochligut	1.22 101.28

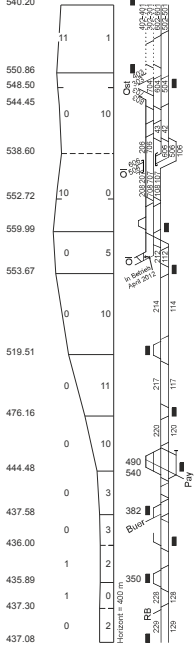

+	Bern	106.16
	Lorraine	Gl. 500 / 600 2.83
	Bern Wylerfeld	103.33
	Bern Wankdorf	0.38 102.95
	Lochligut Süd (Abzw)	0.45 102.50
	Lochligut	1.22 101.28
	vin Otten	1.40
	Zollikofen West (Spw)	99.88 99.86
	Zollikofen	1.05 98.81 (7.46)
	vin Otten	2.66
	Münchenbuchsee	10.12
	Schüpfen	5.57 15.69
	Suberg-Grossaffoltern	4.23 19.92
	Lyss	3.44 23.37
	vin Payerne	2.79
	Busswil	1.96 26.16
	vin Büren a. d. Aare	1.96
	vin Studen Auto	2.39
	Studen BE	1.62 30.51
	Brügg BE	1.62 32.13
	Madretsch	1.46 33.07
	vin Biel RB	1.46 98.84
	Biel/Bienne	99.37

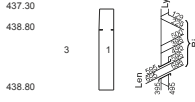

+	Madretsch	32.13
	Biel RB West	1.30 33.44 97.36
	Biel RB	0.76 96.60

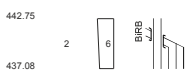

+	Biel Mett	96.25
	Biel/Bienne	3.12 99.37

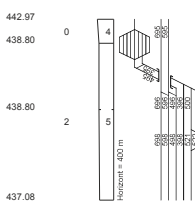

+	Biel Mett (Abzw)	95.81
	Biel RB	0.79 96.60
	Biel RB West	0.76 97.36
	Biel/Bienne	2.01 99.37

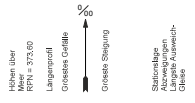

+	Biel/Bienne	99.37
---	-------------	-------

Höhen über Meer
MRFN = 373.60

Langensprofil

Grösste Gefälle

Grösste Steigung

Stationshöhe

Abzweigungen

Abzweigungen

Chasse

Chasse

Blockstationen

vin Neuchâtel

Stuf von Stuf. zur Stuf. der Bahn

Kilometerierung der Bahn

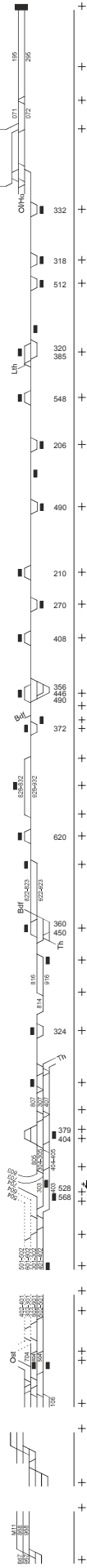
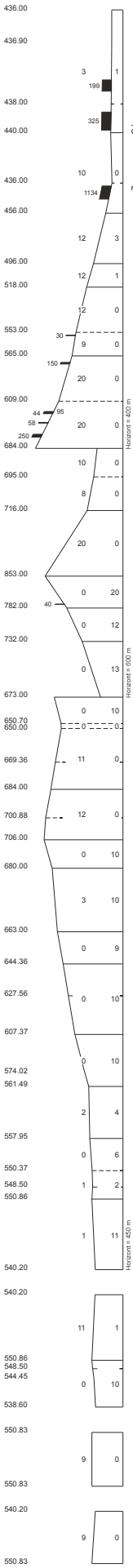

vin Brüng

Luzern

- + Luzern
- + Luzern Einfahrt (Abzw)
- + Heimbach (Spw)
- + Gütsch (Abzw)
- + Fluhmühle (Abzw)
- + **Littau**
- + **Malters**
- + **Schachen LU**
- + Werthenstein
- + **Wolhusen**
vin Langenthal
- + Doppleschwand-Romoos
- + **Entlebuch**
- + Hasle LU
- + **Schüpfheim**
- + **Escholzmatt**
- + **Wiggen**
- + **Trubschachen**
- + **Langnau**
- + Obermatt
vin Burgdorf
Emmenmatt
- + Schüpbach (Signau)
- + Signau
- + Schlossberg (Signau)
- + **Bowil**
- + Zäziwil
- + **Konolfingen**
vin Thun
- + Tagertschi
- + Bachtele (Trimstein)
- + **Worb SBB**
- + **Gümligen Süd (Abzw)**
vin Thun
- + **Gümligen**
- + *Dennigkofen*
- + **Ostermundigen**
- + Wankdorf (Abzw)
- + **Bern Wankdorf**
- + **Bern Wylerfeld**
- + Lorraine Gl. 300 / 400
- + **Bern**
- + **Bern**
- + Lorraine Gl. 500 / 600
- + **Bern Wylerfeld**
Bern Wankdorf
Lochligut Süd (Abzw)
- + **Löchligut**
- + **Bern JKLM**
- + **Bn Weyermannshaus**
- + **Bern**
- + **Bern JKLM**

End v. v. Stat. zu Stat.	Kilometer der Bahn
0.63	95.09
1.10	94.46
1.10	93.36
0.51	92.85
1.02	91.82
2.66	89.18
6.06	83.12
2.98	80.14
3.99	76.15
1.79	74.36
3.89	74.35
4.10	70.46
2.22	66.37
4.07	64.15
7.87	60.07
3.92	52.19
5.13	48.27
5.66	43.13
2.73	37.47
0.64	34.73
2.09	34.09
1.63	32.00
1.72	30.37
1.37	28.65
2.94	27.27
3.82	27.28
2.94	24.34
3.30	20.52
1.92	17.22
2.31	15.30
3.89	12.99
1.41	9.10
3.19	115.37
1.28	113.96
0.51	110.77
0.39	109.48
1.22	108.97
2.80	108.58
2.80	103.33
2.80	106.16
2.80	106.16
0.38	103.33
0.45	102.95
1.22	102.50
1.32	101.28
0.86	96.32
0.86	95.00
0.86	97.18
0.86	96.32

34



SBB

I-FN-FPA-RME

09 Dez 2012 - 14 Dez 2013
(Vers 25)

00-12 Uhr

Nordkopf

Basel St. Jakob

v. u. n. Basel GB

Basel GB VL

Ruchfeld

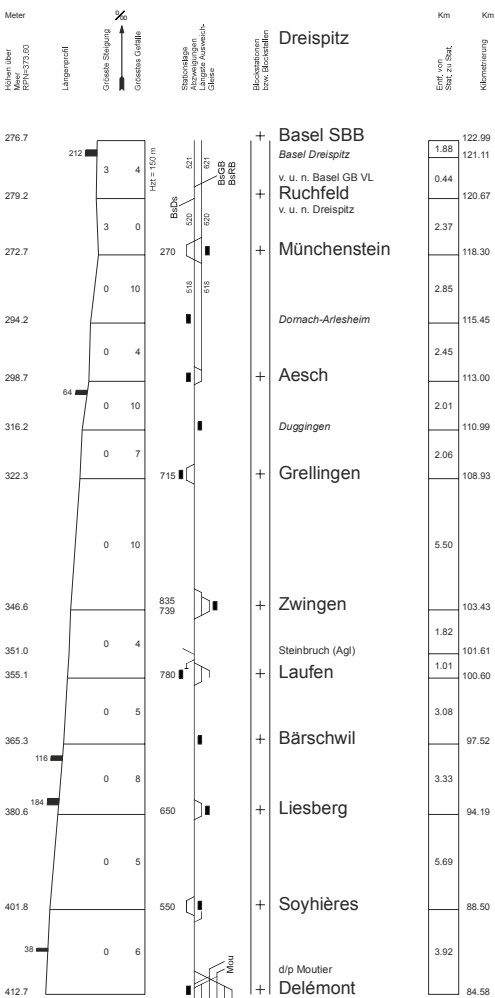

d/p Porrentruy

Höhen über Meer
RFN = 373.00

Längsprofil

Grösstes Gefälle

Grösste Steigung

Stationäre Abweigungen
Längs Ausweich-
Gänge

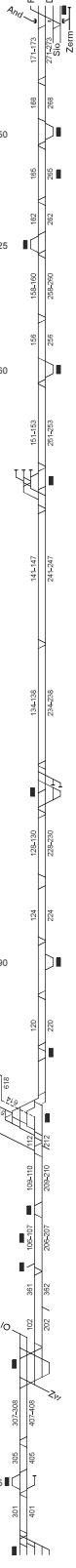
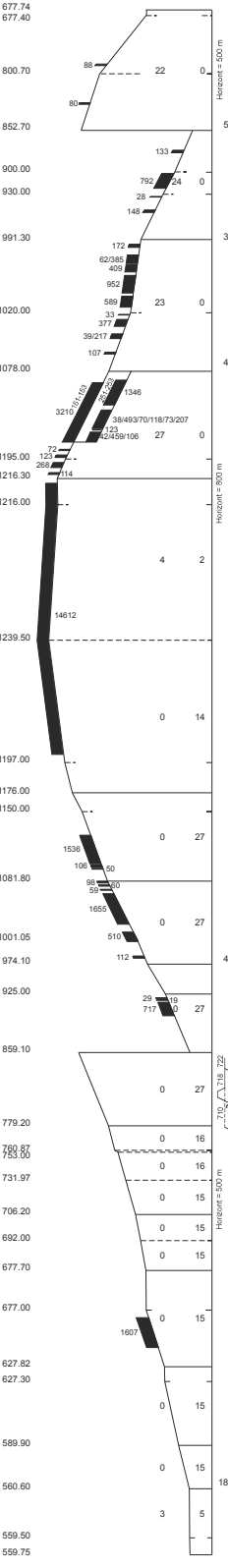

via Domodossola

Brig Tunnel
Brig
Brig-Lötschberg (Abzw)

Gamsen SBB

via Sion

Brig
Brig-Lötschberg (Abzw)

Mundbach (Spw)

Lalden

Eggerberg

Viktoria (Spw)

Ausserberg

Ramerkumme (Spw)

Hohtenn

Stockgraben (Spw)

Goppenstein

Goppenstein Lötschberg (Spw)

Tunnelstation Lötschberg (Spw)

Eggenschwand (Spw)

Kandersteg

Bühl (Spw)

Felsenburg

Fürten (Spw)

Blausee-Mitholz

Grubi (Spw)

Kandergrund

Frutigen

Winklen (Spw)

Wengi (AnG)

Wengi-Ey (Abzw)

Reichenbach im Kandertal

Mülönen

Heustrich-Emdthal

Hondrich Süd (AnG)

Spiez

Spiez (Abzw)

Einigen

Gwatt

Thun

Thun Gruppe B

Thun (Abzw)

Thun

Thun (Abzw)

Lerchenfeld

via Bern

-0.30	73.81
3.16	73.51
3.06	70.35
2.29	67.29
1.30	64.99
2.43	63.70
3.98	61.27
3.11	61.28
4.73	57.30
1.02	54.19
1.41	49.46
7.27	48.44
6.51	47.03
1.69	39.76
1.07	33.26
3.72	31.57
3.11	30.50
1.33	26.78
1.70	23.68
3.20	22.35
3.92	20.65
1.51	17.45
1.59	13.54
1.93	12.03
1.44	11.87
1.68	10.28
2.17	9.97
3.00	8.29
0.89	1.44
3.46	1.68
2.33	2.17
2.62	2.99
1.00	2.90
0.06	0.00
137.59	-0.06
1.00	9.78
	8.90
	5.44
	3.10
	0.49
	137.02

Wichtiges Hinweis:
Um die Lesbarkeit des Fernplanes zu erhöhen,
wurde auf die Darstellung der Vertikal-
abstände verzichtet. Die Höhen sind
20000:20000 verzeichnet.

Entf. von
SBB zu Stat.

Kilometerung
der Bahn

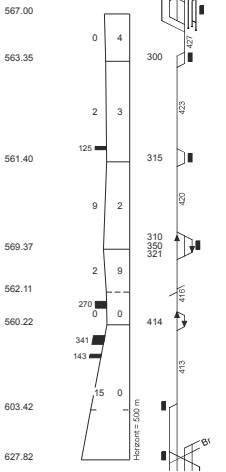

+	Interlaken Ost	27.95
+	Interlaken West	1.93
+		26.02
+		4.01
+	Därligen	22.02
+		3.52
+	Leissigen	18.50
+		18.49
+	Leissigbad (Agl)	1.79
+		16.70
+	Krattighalde	1.30
+		15.40
+		3.44
+	Faulensee	11.96
+		11.88
+	Spiez	2.02
+		9.78

vin Meiringen

vin Zweilütschinen

Interlaken Ost

vin Brig

Spiez

Spiez (Abzw)

vin Thun

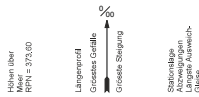

Blockstationen

Entf. von Spiez zu Stat.

Kilometer der Bahn

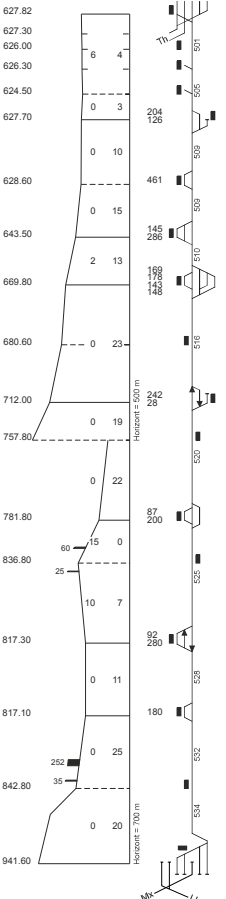

+	Spiez	0.00
+	Spiez (Abzw)	0.89
+	Spiezmoos Süd	0.69
+		1.57
+	Lattigen bei Spiez	0.88
+		2.45
+	Eifeld	1.04
+		3.49
+	Wimmis	1.05
+		4.54
+		2.61
+	Burgholz	7.16
+		2.18
+	Oey-Diemtigen	9.33
+		1.96
+	Erlenbach im Simmental	11.29
+		2.50
+	Ringoldingen	13.79
+		2.31
+	Därstetten	16.10
+		1.54
+	Weissenburg	17.64
+		3.25
+	Oberwil im Simmental	20.90
+		1.73
+	Enge im Simmental	22.63
+		3.28
+	Boltigen	25.90
+		2.98
+	Weissenbach	28.89
+		2.94
+	Grubenwald	31.82
+		3.08
+	Zweisimmen	34.90

vin Lenk

vin Gstaad

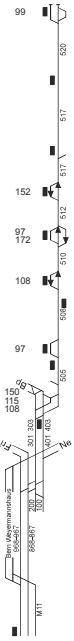
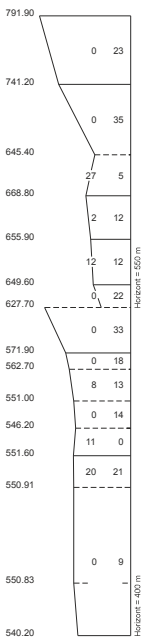

+	Schwarzenburg
+	Lanzenhäusern
	Schwarzwasserbrücke
+	Mittelhäusern
+	Niederscherli
+	Gasel
	Moos
+	Köniz
	Liebefeld
+	Bern Fischermätteli (Abzw)
+	Bern Ausserholligen GBS
+	Bern Holligen
+	Bern Weyermannshaus (Spw)
	Bern JKLM
+	Bern
	Thun
	Thun Gruppe B
	Thun (Abzw)
	Thun

20.87
3.04
17.83
3.18
14.66
1.83
12.82
1.94
10.89
2.01
8.87
1.08
7.80
2.08
5.71
0.72
5.00
1.47
3.52
0.40
3.12
0.41
2.71
0.48
2.23
94.92
1.41
96.32
0.86
97.18

Entf. von Stat. zu Stat.
 Kleinrechnung der Bahn

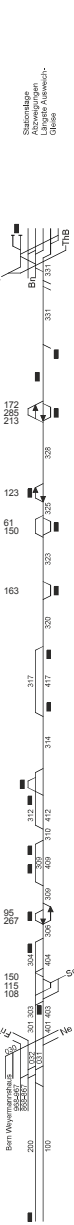

+	Thun (Abzw)
+	Thun
+	Thun (Abzw)
	Lerchenfeld
	Uetendorf Allmend
+	Uetendorf
+	Seftigen
+	Burgistein-Wattenwil
+	Thurnen
+	Kaufdorf
+	Toffen
+	Belp
	Belp Steinbach
+	Falkenhaus (Spw)
+	Kehrsatz
	Kehrsatz Nord
	Breitenacker (Spw)
+	Wabern bei Bern
+	Bern Weissenbühl
+	Bern Fischermätteli (Abzw)
+	Bern Ausserholligen GBS
+	Bern Holligen
	Bern Weyermannshaus (Spw)
+	Bern
	Bern Holligen
	Bern Steigerhubel (Abzw)
	Bern Weyermannshaus
	Bern JKLM
	Bern

34.48
0.87
33.61
1.53
32.08
1.08
30.99
1.70
29.30
3.58
25.72
1.52
24.20
2.86
21.34
2.88
18.47
2.34
16.13
3.43
12.70
0.78
11.92
1.05
10.87
1.21
9.67
0.89
8.77
0.51
8.27
1.70
6.57
1.48
5.09
1.57
3.52
0.40
3.12
0.41
2.71
0.48
2.23
2.18
0.60

Höhen über Meer
RPN = 373.00

Längenprofil
Grösstes Gefälle
Grösste Steigung

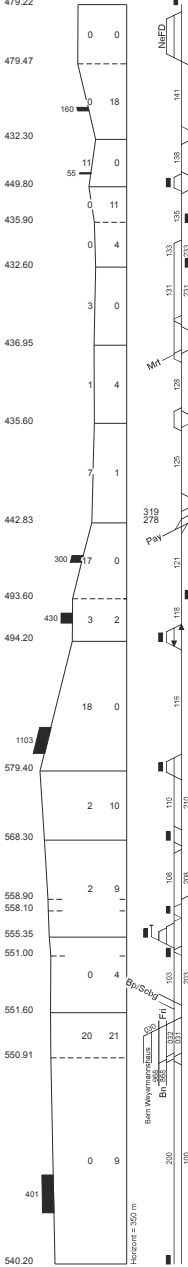

Station	Blöckstationen	Entf. von Str. zu Str.	Kürzeste Distanz der Bahn
Bern			0.60
Bern Weyermannshaus (Spw)			2.23
Bern Holligen			2.71
Bern Bümpliz Nord			3.31
Bern Brünnen			5.32
Niederbottigen (AGI)			5.89
Riedbach			8.49
Rosshäusern			11.45
Gumpelen			33.12
Fanelwald			34.20
Zihlbrücke			35.18
Marin-Epagnier			36.72
St-Blaise-Lac			38.74
Neuchâtel-Mail			42.03
Neuchâtel			75.29

Neuchâtel

Neuchâtel faisceau D

Neuchâtel-Mail

Neuchâtel

Neuchâtel-Mail

St-Blaise-Lac

Marin-Epagnier

Zihlbrücke
Fanelwald
Gumpelen

Ins

v/n Murten

Müntschemier

Kerzers

v/n Payerne

Ferenbalm-Gurbrü

Gümmenen

Rosshäusern

Riedbach

Niederbottigen (AGI)
Bern Brünnen

Bern Bümpliz Nord

Bern Stöckacker

Bern Holligen

Bern Weyermannshaus (Spw)

Gl. 100 / 200

Bern

Bern Holligen

Bern Weyermannshaus (Spw)

Gleise 967 / 867

Bern JKLM

Gleise P (J2,J7,J8)

Bern

Bern Holligen
Bern Steigerhubel (Abzw)

Bern Weyermannshaus

Bern JKLM

Gleise G (J1, M11)

Bern

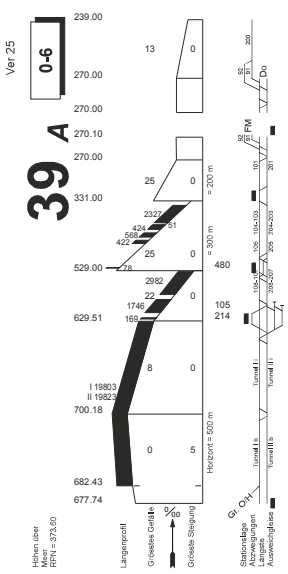

Domodossola II	191.34
Domodossola FM	186.12
Domodossola (bif)	185.04
Domodossola (bif)	186.28
Domodossola (bif)	185.04
Preglia	182.45
Rio Rido	8.71
Mognatta	6.27
Varzo	173.75
Galleria elicoidale	6.27
Iselle di Trasquera	167.48
	11.13
Staz. della Galleria Sempione	156.35
	9.20
Brig Tunnel	147.15
Brig	145.55

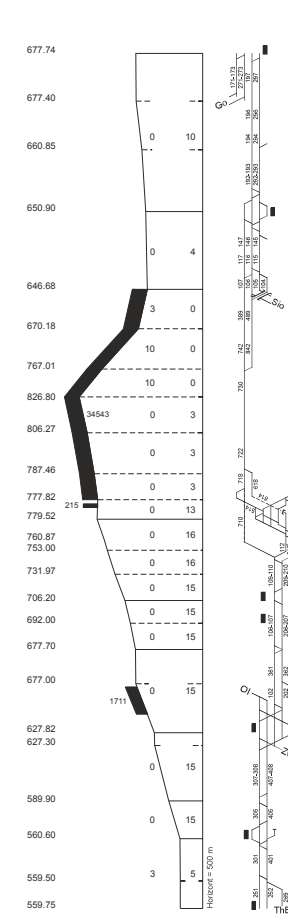

Brig	145.55
Brig Löttsberg (Abzw)	73.51
Brig	145.55
Brig Löttsberg (Abzw)	145.25
Gliser Grund	3.81
Gamsen SBB	141.44
	4.71
Visp	136.73
	135.90
	135.89
	3.32
St. German (Abzw)	133.40
	50.12
Löttschen	43.84
Ferden (Spw)	8.62
	35.22
Mitholz	13.20
	22.02
Adelrain (Abzw)	6.26
	15.76
Frutigen Nordportal (Abzw)	1.12
Frutigen	14.65
	14.26
	1.27
	13.54
Winklen (Spw)	1.51
Wengi (AGI)	12.03
	11.87
Wengi-Ey (Abzw)	0.16
	11.87
Reichenbach i/K.	10.11
	9.90
	9.97
Mülmen	1.44
	8.29
Heustrich-Emdthal	1.68
	5.16
Hondrich Süd (AGI)	2.17
	2.99
	2.90
Spiez	3.00
Spiez (Abzw)	0.00
	-0.106
	9.78
	0.89
	8.90
Einigen	3.46
	5.44
Gwatt	2.33
	3.10
Thun Schadau (Abzw)	2.62
Thun	1.00
	0.49
	0.06
	137.59
	137.02

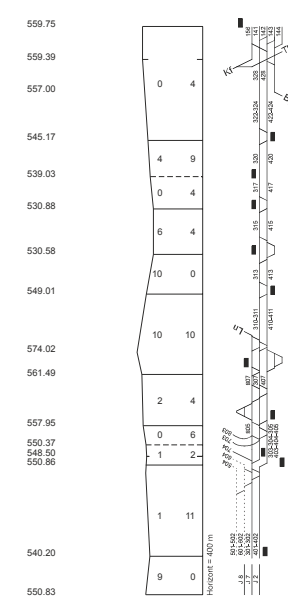

Thun	137.02
Thun (Abzw)	0.87
	136.15
Lerchenfeld	1.52
	134.63
Uttigen	3.53
	131.10
Kiesen	2.79
	128.30
Wichtrach	2.57
	125.73
Münsingen	3.60
	122.13
Rubigen	3.09
	119.04
Allmendingen	3.67
Gümligen Süd (Abzw)	115.37
Gümligen	1.41
	113.96
Dennigkofen	3.19
Ostermündigen	3.19
	110.77
Wankdorf (Abzw)	1.28
Bern Wankdorf	0.51
Bern Wylterfeld	109.48
	0.30
	108.68
	103.33
Lorraine	2.80
Bern	106.16
	97.18
Bern JKL M	0.86
	96.32

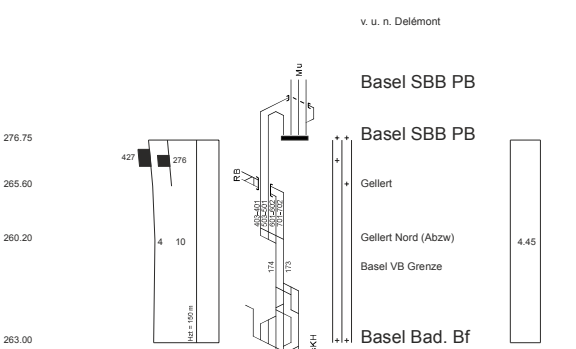
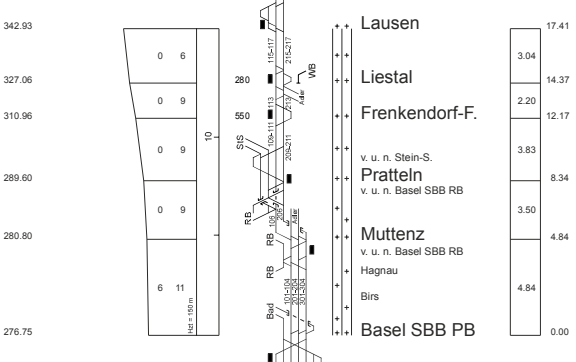
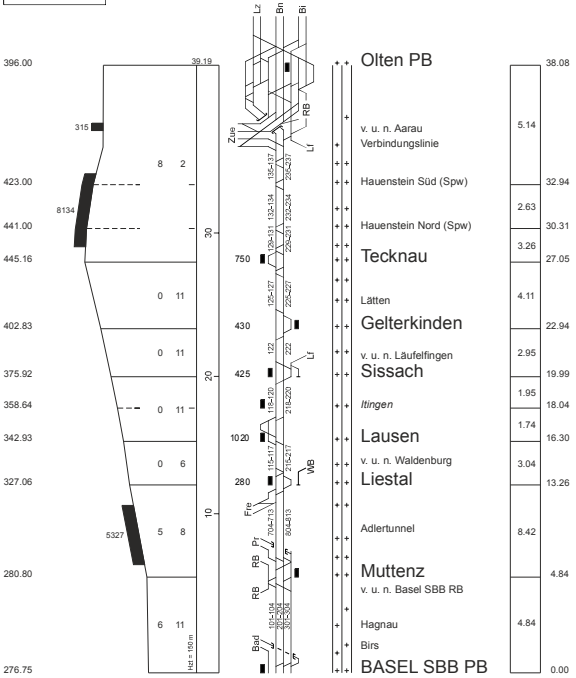

Meter

Höhen über Meer (NN) = 373.60

Längsprofil

Größtes Gefälle

Größte Steigung

Stationen

Abzweigungen

Längste Ausweich

Gleise

Blockstationen bzw. Blockstellen

Km

Km

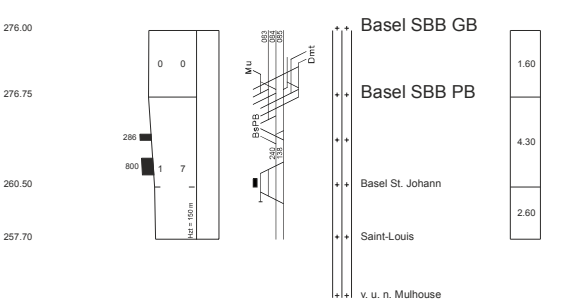

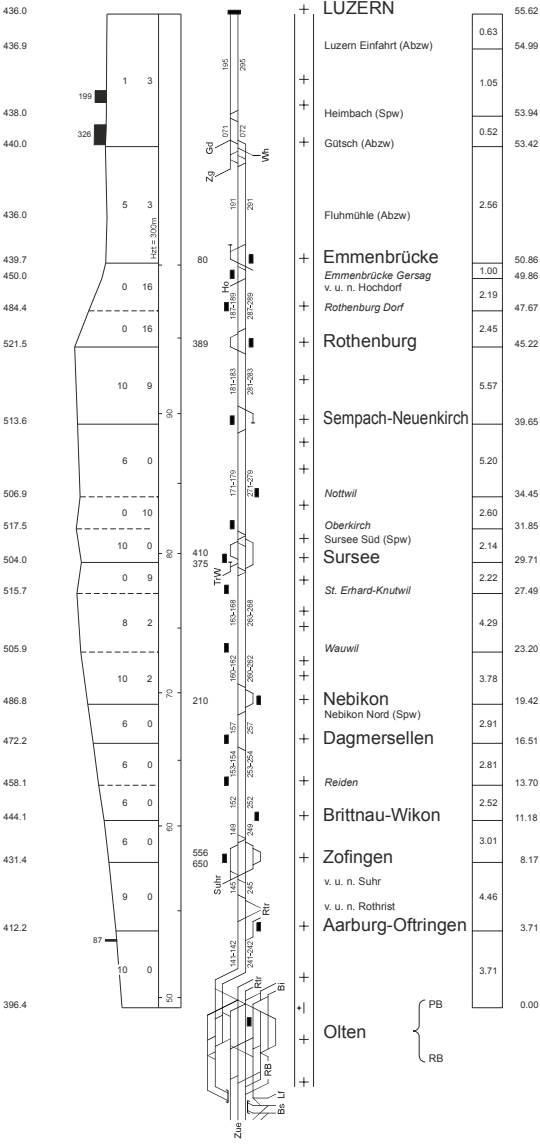

Meter
Höhen über Meer = 373.60
RFN = 373.60

Längsprofil
Grosste Steigung
Grosste Gefälle
Kilometerung

Stationen
Abzweigungen
Längste Ausweich.
Gleise

Blockstationen bzw. Blockstellen

Olten PB
v. u. n. Bern

Km
Entf. vom Stat. zu Stat.
Entf. vom Ausgangspunkt

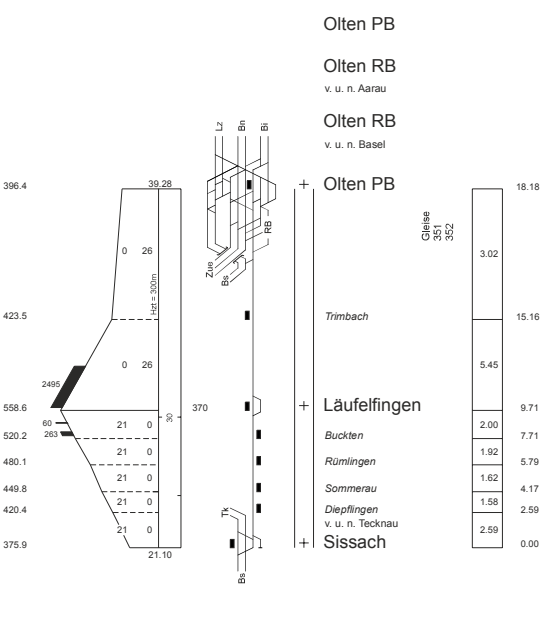

v. u. n. Basel

v. u. n. Brünig

LUZERN

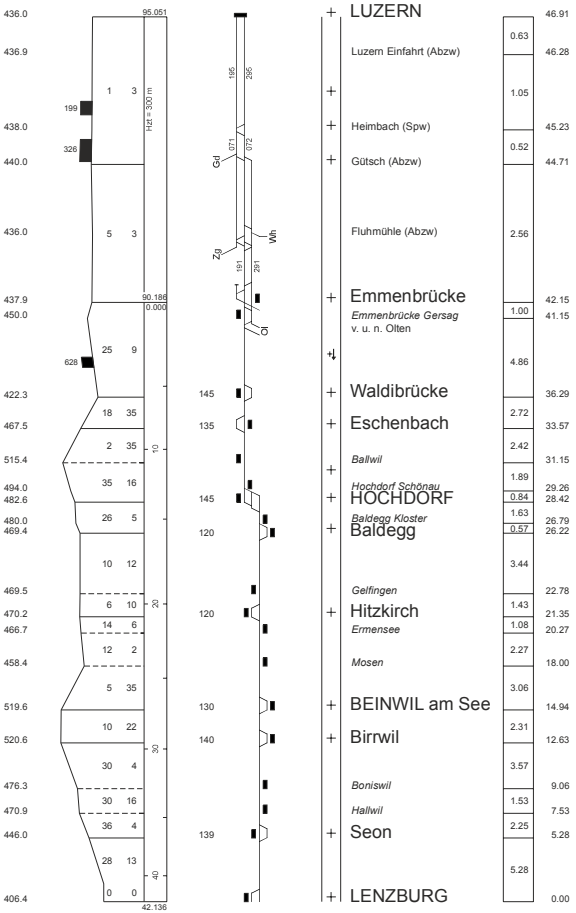

Meter
Höhen über Meer
RPN1 = 373,60

Langenprofil

Grösste Steigung
Grösste Gefälle
Kilometerleistung

Stationen
Abzweigungen
Längliche Ausweich-
Gleise

Blockstationen
bzw. Blockstellen

LENZBURG

Km
Entf. vom Stat. zu Stat.

Km
Entf. vom Ausgangspunkt

Rupperswil

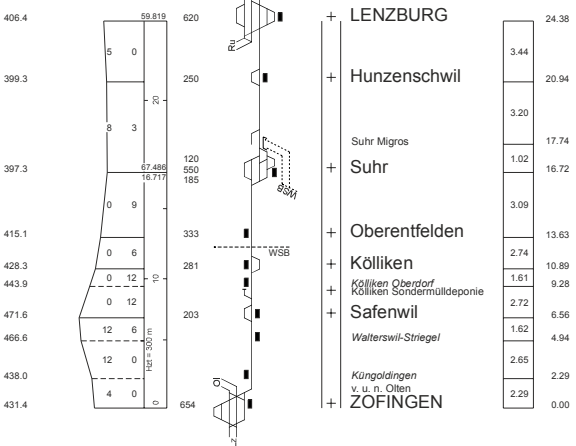

v. u. n. Luzern

12-24 Uhr

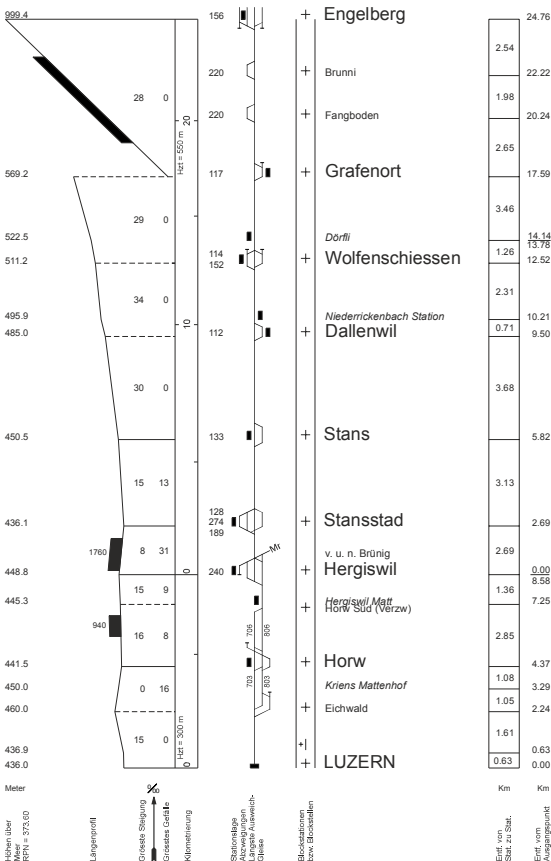

00-12 Uhr

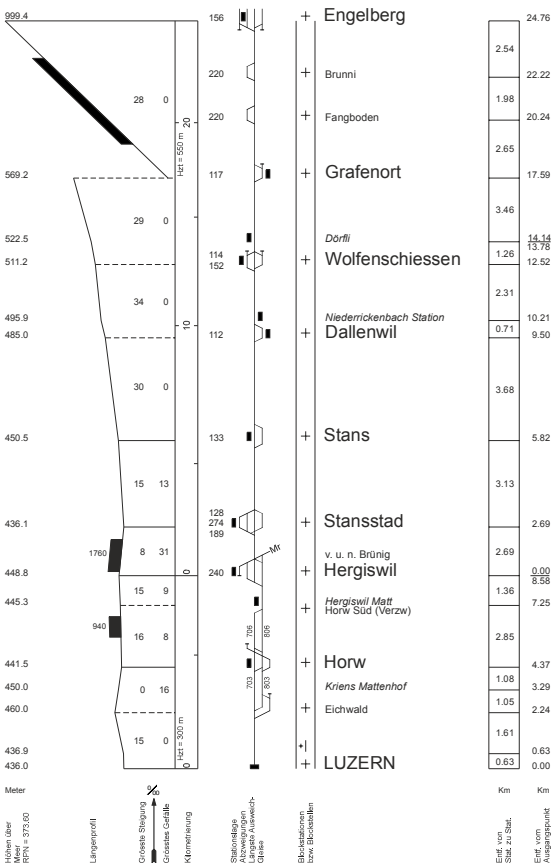

00-12 Uhr

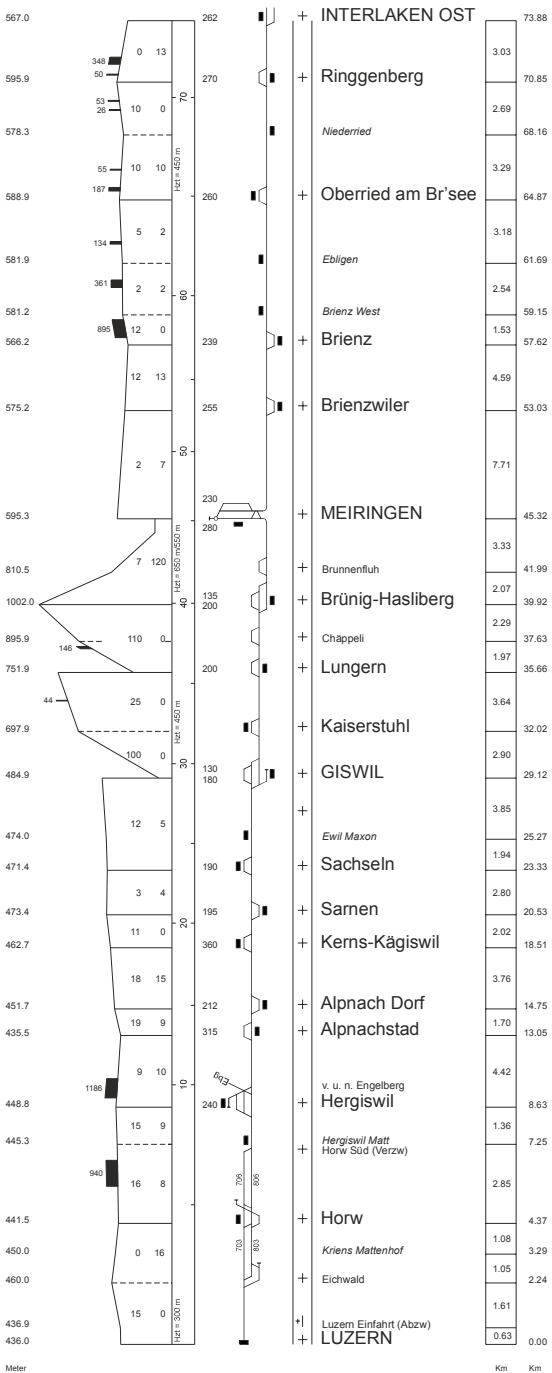

Meter
 Höhen über Meer
 RPN = 373.60
 Längsprofil
 Grösste Steigung
 Grösstes Gefälle
 Kilometerleistung
 Stationstage
 Abzweigungen
 Längste Auswech-
 Grösse
 Blockstellen
 bzw. Blockstellen
 km
 km
 Entf. von Stat. zu Stat.
 Entf. vom Ausgangspunkt

00-12 Uhr

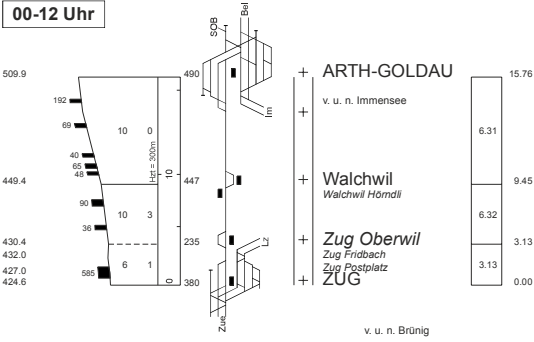

v. u. n. Brünig

LUZERN

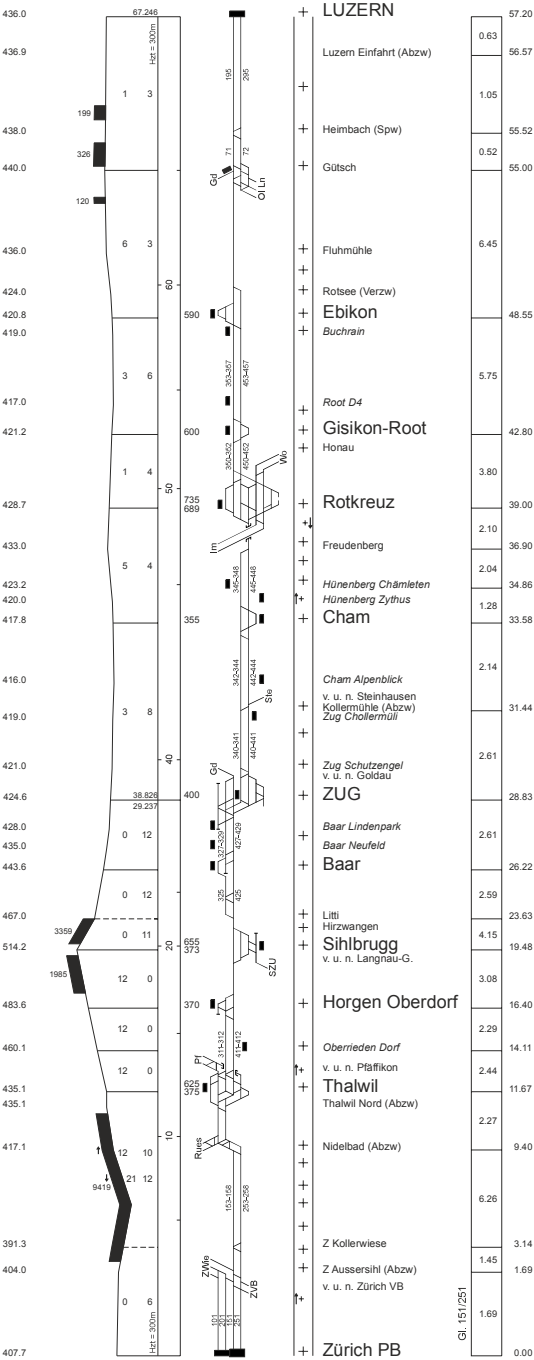

Zch Aussersihl

Zch Vorbahnhof

Meter
Höhe über Meer
RFN = 373.60

Längsprofil
Grösste Steigung
Grösstes Gefälle
Kilometerleistung

Stationen
Längs- und Querschnitt
Längs- und Querschnitt
Gleise

Blockstationen
z.B. Blockstellen

Km
Entf. vom Stat. zu Stat.
Entf. vom Ausgangspunkt

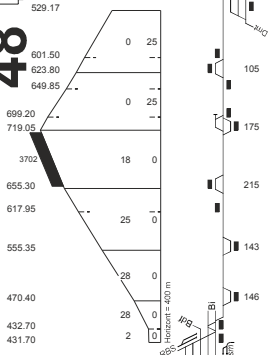

v.u.n. Delémont

Moutier	22.09	23.05
Grandval	18.84	19.80
Crémines	17.77	18.74
Corcelles BE	16.58	17.54
Crémines-Zoo	14.60	15.56
Gänsbrunnen	13.62	14.58
Oberdorf SO	9.63	10.59
Im Holz	8.02	8.98
Lommiswil	5.34	6.30
Langendorf	1.91	2.87
Solothurn West	0.00	0.96
Solothurn		

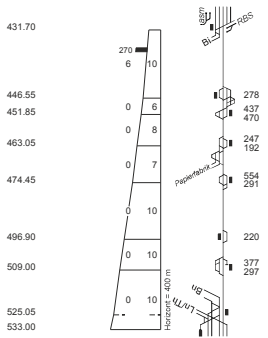

v.u.n. Olten

Solothurn		0.00
Biberist RM	4.69	4.69
Gerlafingen	1.16	5.85
Wiler	2.17	8.02
Utzenstorf	2.56	10.58
Aefligen	3.86	14.44
Kirchberg-Alchenflüh	2.19	16.63
Burgdorf Buchmatt	3.04	19.67
Burgdorf	1.07	20.74

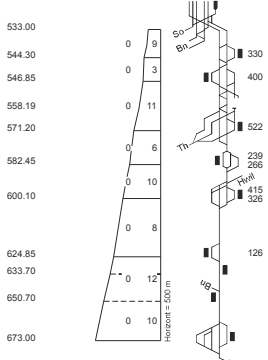

Burgdorf	20.74	0.00
Burgdorf Steinhof	1.90	1.90
Oberburg	1.66	3.56
Schachen	3.37	6.93
Hasle-Rüegsau	27.67	6.93
Lützelflüh-Goldbach	30.05	9.31
Ramsei	2.38	2.38
	2.36	11.67
	3.97	15.64
Zollbrück	36.38	16.89
Neumühle	37.63	18.72
Obermatt	39.46	21.47
Langnau	42.21	21.47

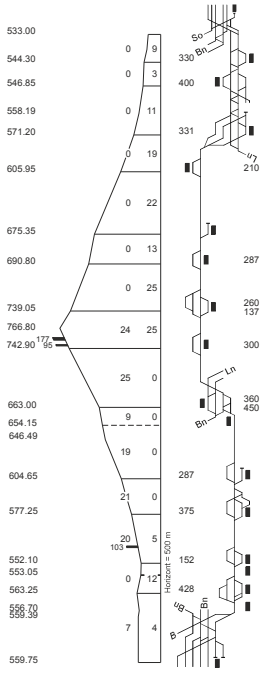

v.u.n. Luzern

Burgdorf		0.00
Burgdorf Steinhof	1.90	1.90
Oberburg	1.66	3.56
Schachen	3.37	6.93
Hasle-Rüegsau	0.00	6.93
v/h Langnau	2.56	9.49
Schafhausen i/E	4.27	13.76
Bigenthal	6.83	15.82
Walkringen	8.89	19.02
Biglen	3.20	21.60
Grosshöchstetten	12.09	25.67
v/h Langnau	14.67	26.89
Konolfingen	18.74	30.58
v/h Bern	19.96	33.01
Stalden i/E	3.69	36.31
Dessigkofen	3.20	37.18
Oberdiessbach	23.65	38.44
Brenzikofen	26.08	39.66
Heimberg	3.30	39.88
Ladeli	29.38	
Steffisburg	30.25	
Schwäbils	31.51	
Thun (Abzw)	32.73	
Thun	32.95	
Thun (Abzw)	0.87	
Thun	33.82	
Thun Schadau (Abzw)		

Höhen über Meer
RPN = 373.00

Längsprofil
Grösste Gefälle
Grösste Steigung

Stationenlage
Längsprofil
Längsprofil
Längsprofil

Blockstationen

Stuf von Stuf zur Stuf.
Kilometerung der Bahn

Langenthal

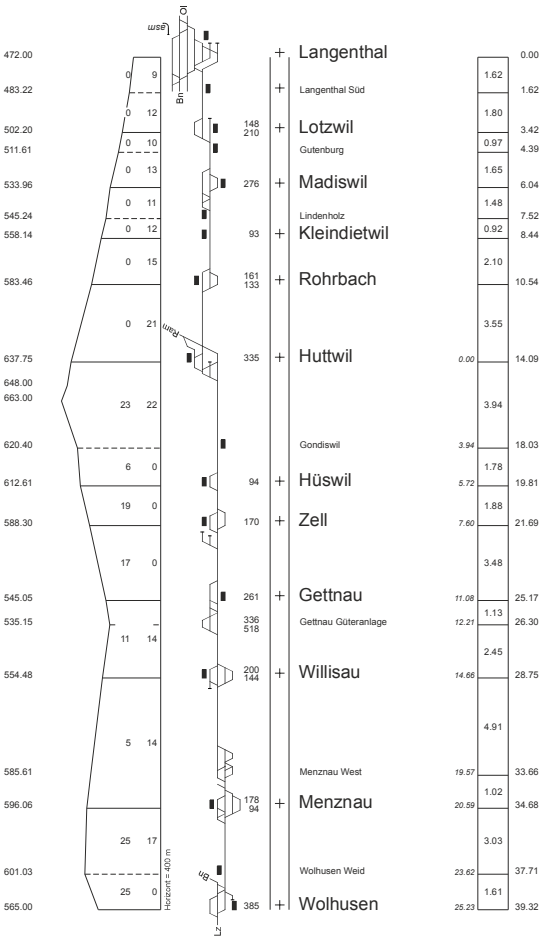

Wolhusen

Höhen über Meer (N) RHN = 373.60
 Langenprofil
 Grosses Gattale
 Grosse Steigung
 Stationslage
 Ausweichungen
 Ausweichungsbereich
 Gleise
 Blockstationen
 Entf. von SBB zu Strab.
 Klimometrie
 der Bahn

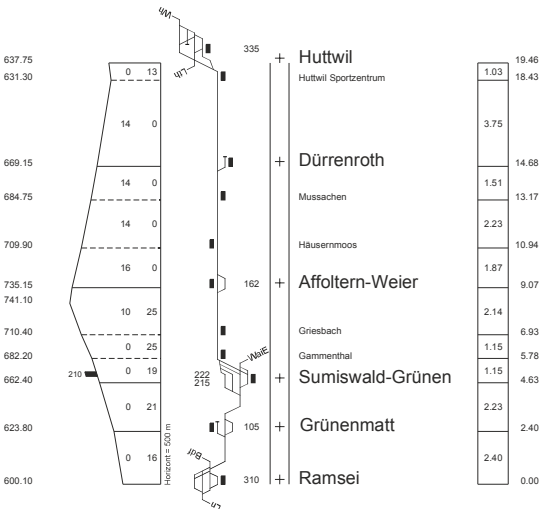

Ramsei



I-FN-FPA-RME

09 Dez 2012 - 14 Dez 2013
(Vers 25)

00-12 Uhr

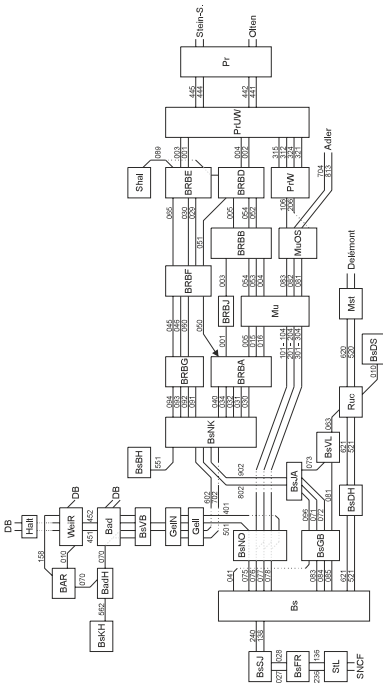

v. u. n. Olten

+ Pratteln

v. u. n. Schweizerhalle
+ Basel RB Gr E

+ Basel RB Gr F
v. u. n Gr A

+ Basel RB Gr G

Nordkopf

+ Gellert

Gellert Nord (Abzw)

+ Basel Bad. Bf.

+ Weil (Rhein)

+ Basel Bad. Rbf.

+ Basel Bad. Bf.

+ Basel Bad Rbf Kleinh. Abzw.

+ Basel Bad. Rbf.

+ Basel Bad. Bf.

+ Basel Bad Rbf Kleinh. Abzw.

+ Basel Kleinh. Hafen

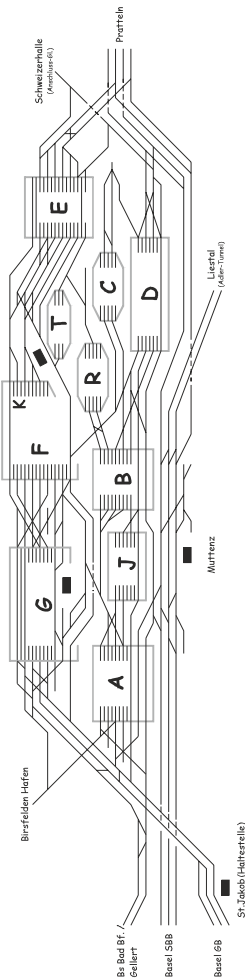

v. u. n. Stein-S.

+ Pratteln

+ Basel RB Gr D

Basel RB Gr B

+ Muttenz

+ Basel RB Gr A

Nordkopf

Basel St. Jakob

+ Basel SBB GB
v. u. n. Basel SBB (GI 041)

+ Basel SBB PB

+ Basel St. Johann

+ Saint-Louis

+ Basel RB Gr A

v. u. n. Gr G
Nordkopf

+ Birsfelden Hafen

Lupfig

v. u. n. Othmarsingen

- Brugg AG Süd (Abzw)
- Brugg VL
- Brugg AG Nord (Abzw)

Turgi

v. u. n. Zürich

Brugg AG

Brugg AG Nord (Abzw)

Villnachern (Spw)

Schinznach Dorf

Effingen

Kirchmatt (Spw)

Hornussen
Buchhalde (Spw)

Frick

Niederfeld (Spw)
Eiken

v. u. n. Koblenz

Stein-Säckingen

Mumpf

Dossenboden (Spw)

Möhlin

Rheinfelden

Rheinfelden Augarten

Kaiseraugst

Pratteln Salina Raurica

Pratteln

Muttenz

Basel SBB PB

Basel St. Johann

St-Louis

v. u. n. Mulhouse-Ville

Pratteln

Basel RB Gr D

Pratteln

Basel RB Gr E

Basel RB Gr G

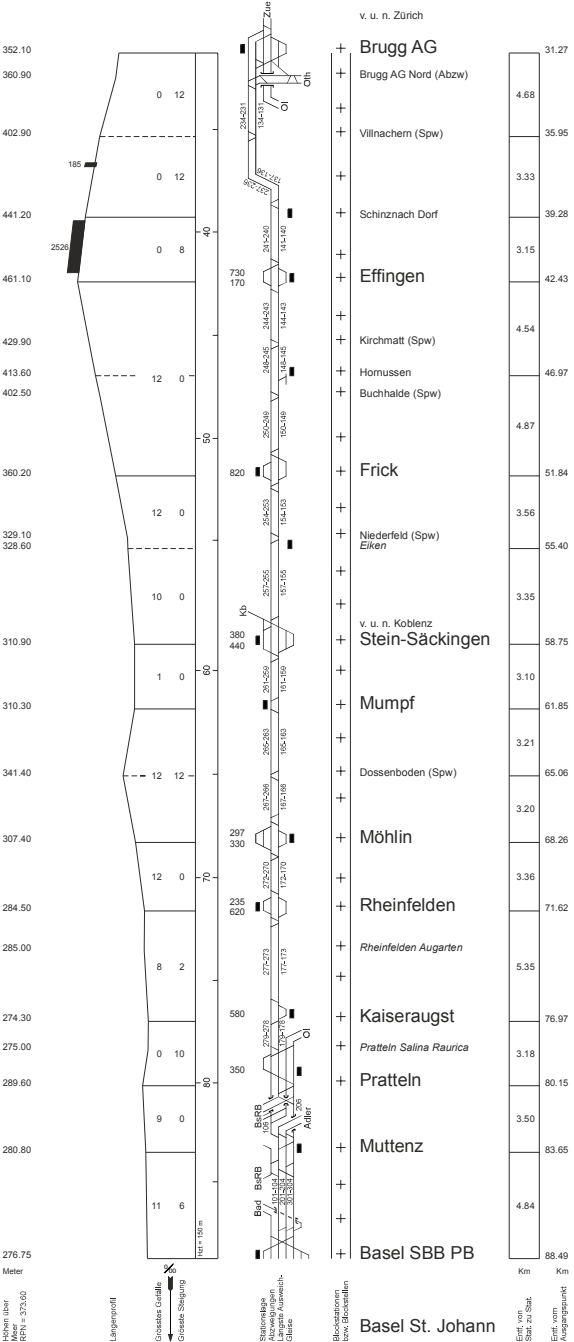

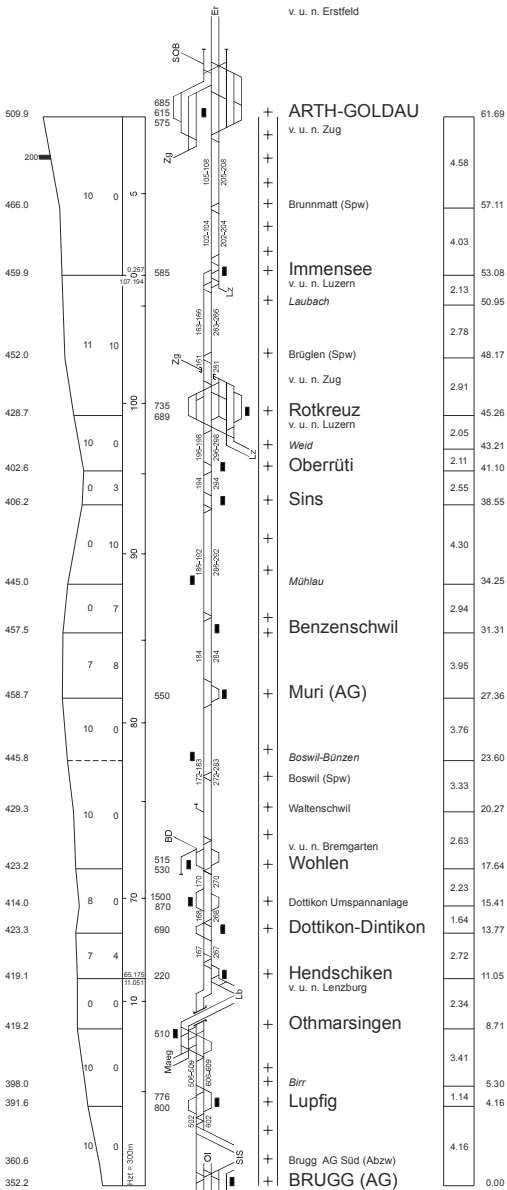

Meter

v. u. n. Basel

Km Km

Höhen über Meer
RNH = 273.60

Längsprofil

Grösste Steigung
Grösste Gefälle
Kilometerleistung

Streckenanlage
Abstand
Längste Ausweich-
Gleise

Blockstationen
bzw. Blockstellen

BRUGG (AG)

Erläut. von
Stütz- u. Stütz-

Erläut. von
Ausgangspunkt

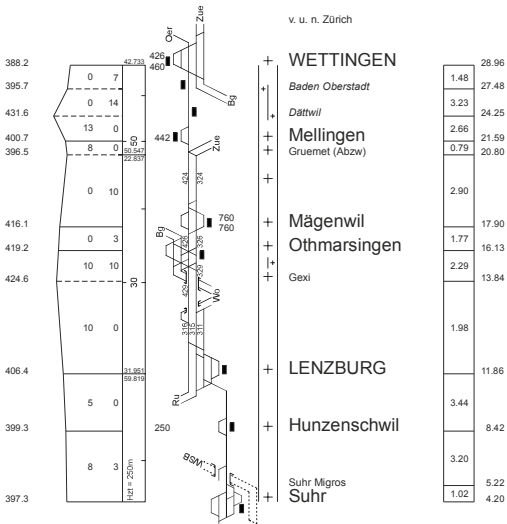

v. u. n. Zürich

v. u. n. Andermatt

Göschenen

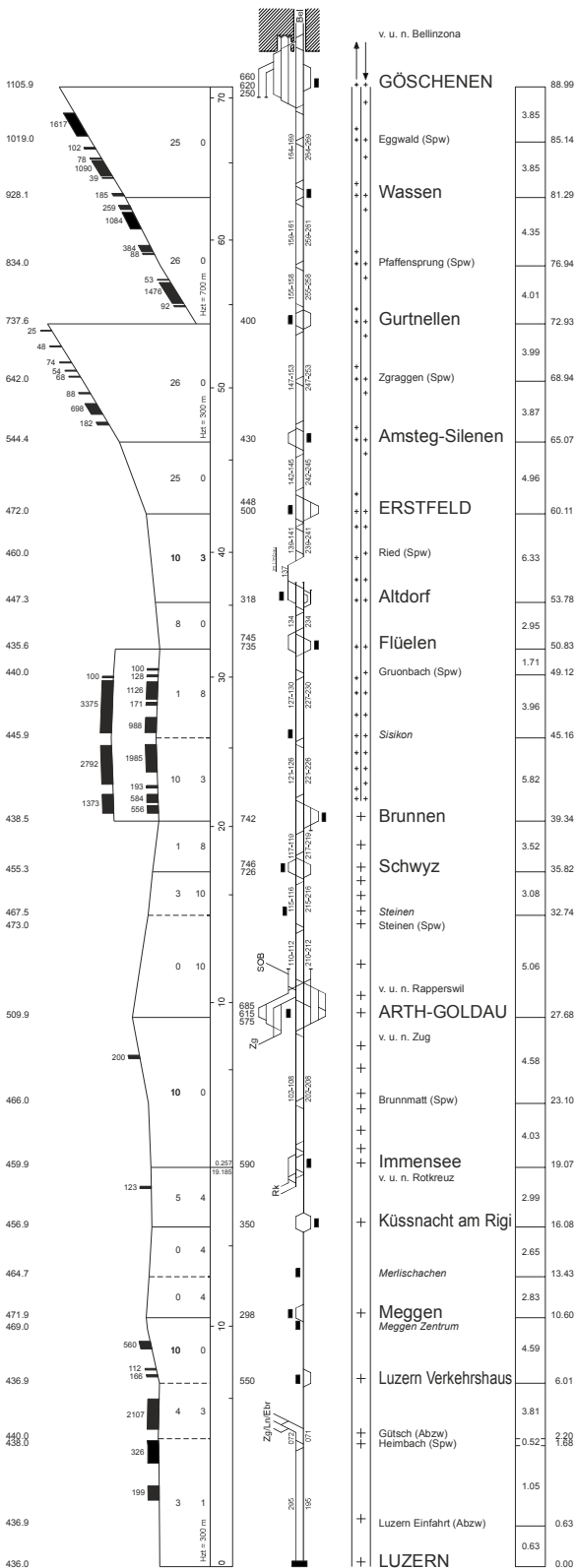

Meter

Km Km

Höhen über Meer
RPN = 373.00

Längsprofil

Grösstes Gefälle
Grösste Steigung
Kilometerung

Stationen
Abzweigungen
Graben
Kilometer

Blockstationen
bzw. Blockstellen
LUZERN
v. u. n. Brünig

Einf. von Stat. zu Stat.

Einf. vom Ausgangspunkt

I-FN-FPA-RME

09 dicembre 2012 - 14 dicembre 2013
(Vers 25)

00-12 ore

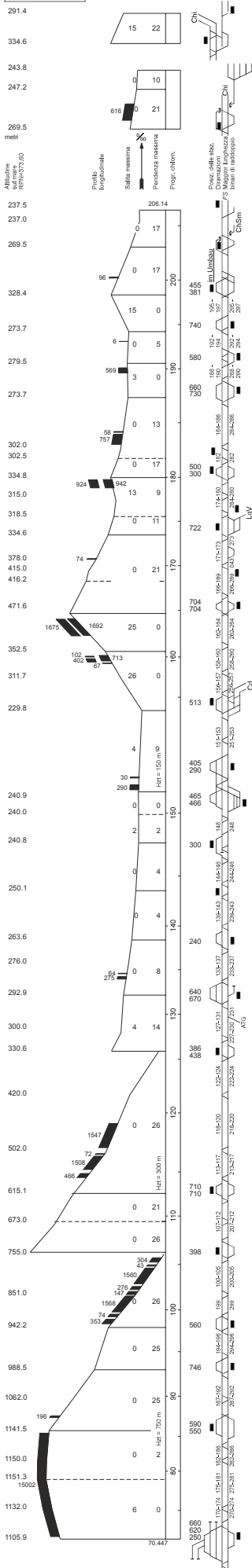

da e per Como

Chiasso

+ Lugano Vedeggio	107.34
+ Taverner-Torricella	103.55
+ Chiasso SM	135.61
+ Balerna	133.06
+ Chiasso	135.67
+ Balerna	133.06
+ Mendrisio	128.24
+ Capolago-R.S.V.	124.14
+ Maroggia-Melano	120.56
+ Melide	116.75
+ Lugano Paradiso (c bin)	112.74
+ Lugano Paradiso	112.37
+ Lugano	109.98
+ Lamone (c bin)	107.40
+ Lamone-Cadempino da e per Lugano Vedeggio	105.63
+ Taverner-Torricella	103.55
+ Sigirino	100.85
+ Mezzovico (c bin)	99.55
+ Mezzovico	98.38
+ Riviera-Bironico	94.74
+ Al Motto (c bin)	90.92
+ Viganza (c bin) da e per Luino/Locarno	87.57
+ Giubiasco	93.57
+ Bellinzona Sud	80.42
+ Bellinzona Collegamento S. Paolo	79.29
+ Bellinzona Nord (bif)	2.50
+ Castione-Arbedo	76.79
+ Claro	73.00
+ Osogna-Cresciano	67.49
+ Giustizia (dira)	6.17
+ Biasca	61.32
+ Pasquerio (bin rac)	6.29
+ Pollegio Nord	55.03
+ Bodio	4.37
+ Giornico (c bin)	50.66
+ Pianotondo (c bin)	46.96
+ Lavorgo	42.12
+ Chiggogna (c bin)	38.93
+ Faido	35.57
+ Pardorea (c bin)	31.47
+ Rodi-Fiesso	27.37
+ Ambri-Piotta	22.58
+ Sordo (c bin)	19.21
+ Airolo	15.74
+ Gottardo Sud (c bin)	10.85
+ Gotthard Nord (Spw)	4.90
+ Göschenen	0.00

v. u. n. Erstfeld

55



FFS

I-FN-FPA-RME

09 dicembre 2012 - 14 dicembre 2013

(Vers 25)

00-12 ore

da e per Domodossola

Locarno

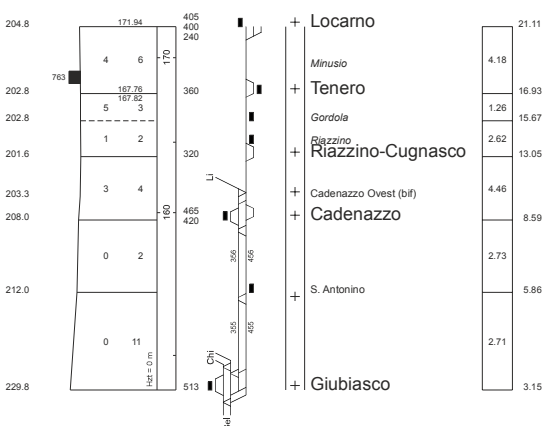

metri

da e per Airola

Km

Km

Altitudine
sull'altitudine
RPM=373.80

Profilo
longitudinale

Salita massima
Pendenza massima

Progr. chilom.

Press. oltre staz.
Max. lunghezza
binari di raddoppio

Staz. di sbocco
risp. ponti di sbocco

Dist. fra
le stazioni

Dist. dall'inizio
di origine



SBB 60

I-FN-FPA-ROT

09 Dez 2012 - 14 Dez 2013 (Vers 25)

Winterthur GB

0-12

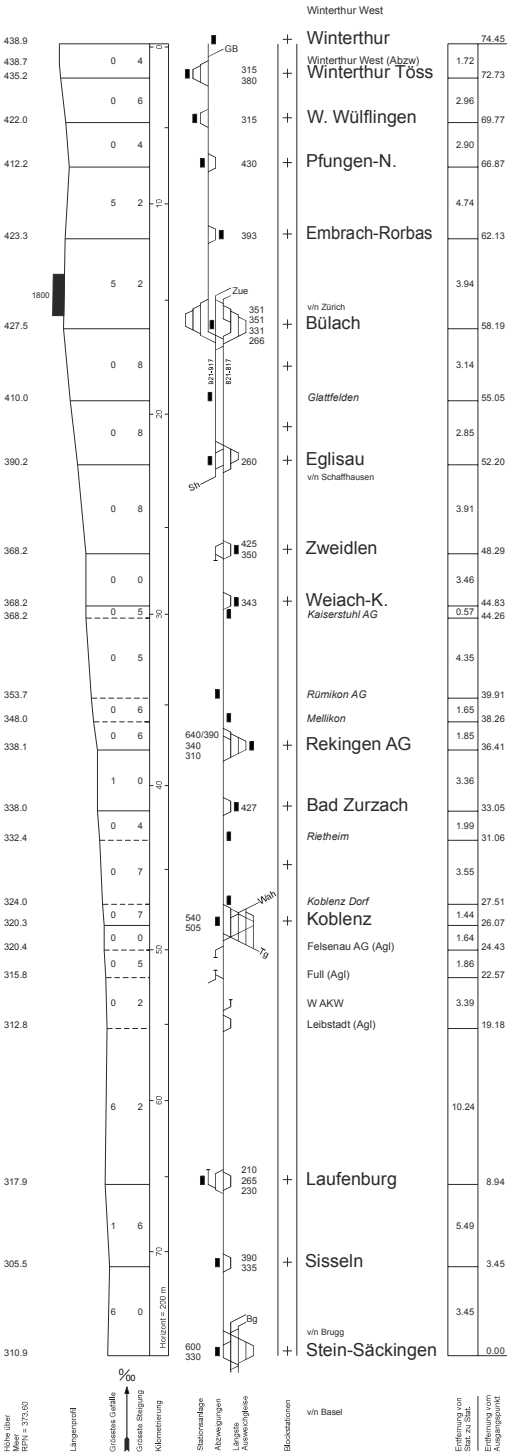

Mumpf

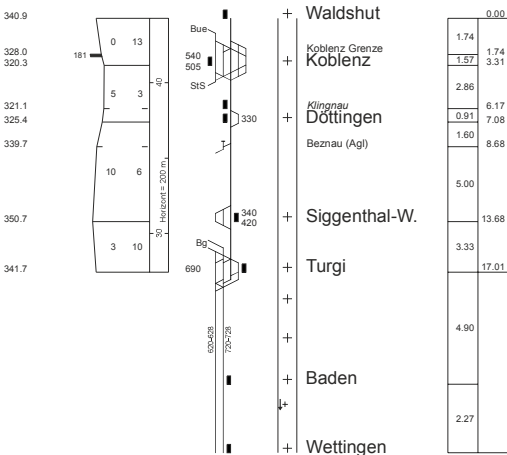



SBB 61

I-FN-FPA-ROT

09 Dez 2012 - 14 Dez 2013 (Vers 25)

0-12

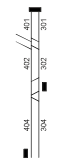

+	Zürich PB A 3-18	0.00
+	Q 51-54	
+	Z Viadukt (Abzw)	1.40
+	Z Wipkingen	1.49
+	Z Oerlikon	2.89
+		2.42
+		5.31

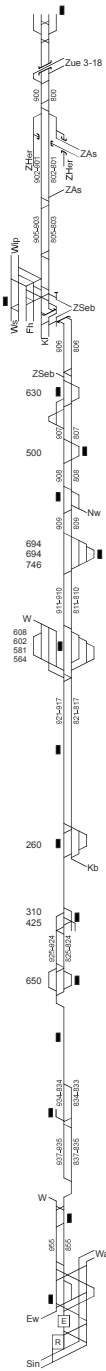
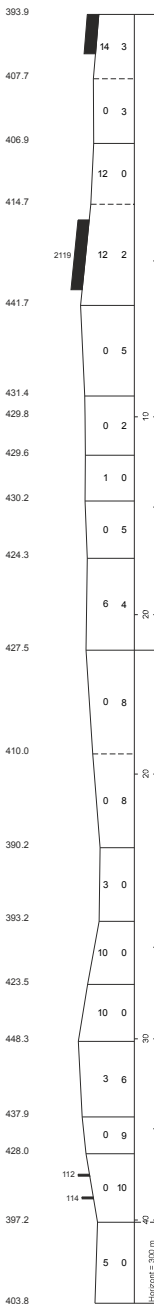

+	Zürich PB S21-24	0.00
+	Z Langstrasse	1.92
+	Z Hardbrücke	1.92
+	v/n Altstetten	1.35
+	Hard Käferberg (Abzw)	3.27
+	Z Oerlikon	3.08
+		6.35
+		2.49
+	Glattbrugg	8.84
+	Tankanlage Rümliang	3.34
+	Rümliang	12.18
+	Oberglatt	2.59
+	v/n Niederweningen	14.77
+		2.12
+	Niederglatt	16.89
+		5.06
+	Bülach	21.95
+		3.14
+	Glattfelden	25.09
+		2.85
+	Eglisau	27.94
+	v/n Koblenz	1.35
+	Hüntwangen-Wil	29.29
+		3.44
+	Rafz	32.73
+		3.12
+	Lottstetten	35.85
+		2.34
+	Jestetten Süd (Verzw)	38.19
+	Jestetten	40.02
+		1.83
+	Fischerhölzli (Verzw)	43.59
+	v/n Winterthur	3.57
+	Neuhausen	45.81
+		2.22
+		2.23
+	Schaffhausen	48.04

Höhe über Meer RHN=373,00

Längsprofil

Großes Gefälle

Große Steigung

Kilometer

%

Stationsanlage

Abzweigungen

Längs-Abzweigungen

Blockstationen

Schaffhausen
Schaffhausen W203
Herblingen

Thayngen
Bietingen
Gottmadingen

Singen (Htw.)

DB

Entfernung von Satz zu Satz

Entfernung vom Ausgangspunkt

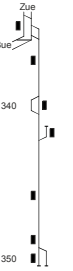
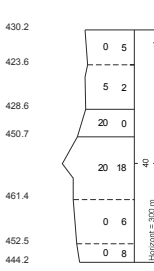

+	Oberglatt	0.00
+	Niederhasli	1.92
+		2.40
+	Dielsdorf	4.32
+	Steinmaur	1.33
+		5.65
+		2.86
+	Schöllisried-Oberweningen	8.51
+		2.47
+	Niederweningen Dorf	10.98
+	Niederweningen	1.06
+		12.04

Höhe über Meer RPN = 773.00

Langenprofil
Grösstes Gefälle
Grösste Steigung
Klometrierung

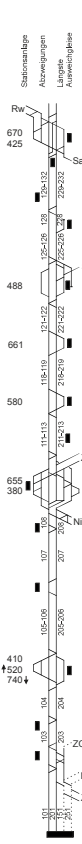
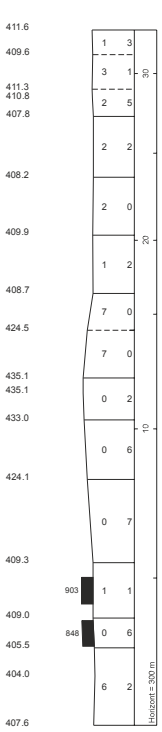

Blockstationen

Altendorf

- + vln Ziegelbrücke
- + Pfäffikon SZ
- + Freibach SBB
- + Bäch
- + Häfen Bäch (Spw)
- + Richterswil
- + vln Samstagen
- + Wädenswil
- + Au ZH
- + Horgen
- + Oberrieden
- + vln Zug
- + Thalwil
- + Thalwil Nord (Abzw)
- + Rüslikon
- + Kilchberg
- + Z Wollishofen
- + Z Enge
- + Z Wiedikon
- + Z Aussersihl (Abzw)
- + vln Zürich VB
- + Zürich PB

Siedlung von SBB zu SBB
Entfernung vom Ausgangspunkt

1.73	33.08
2.34	31.35
29.01	
28.37	
0.64	
1.27	27.10
3.48	
23.62	
3.26	
20.36	
3.93	
16.43	
2.54	
13.89	
2.14	
11.75	
1.45	
10.30	
2.00	
8.30	
2.83	
5.47	
1.87	
3.60	
1.00	
2.60	
0.91	
1.69	
0.00	

SBB 63 A

LFN-FPA-ROT
09 Dez 2012 - 14 Dez 2013 (Vers 25)

0-6

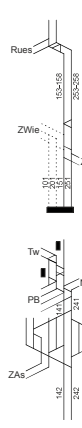

- + Thalwil Nord (Abzw)
- + Nidelbad (Abzw)
- + Z Kollerwiese
- + Z Aussersihl (Abzw)
- + vln Zürich VB
- + Zürich PB
- + Z Giesshübel
- + Z Wiedikon
- + Z Aussersihl (Abzw)
- + Zürich VB
- + Z Altstetten

11.67	
2.27	9.40
6.26	
3.14	
1.45	1.69
1.69	0.00
1.03	
4.18	
2.10	2.08
2.08	0.00

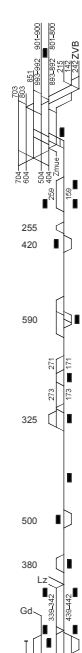
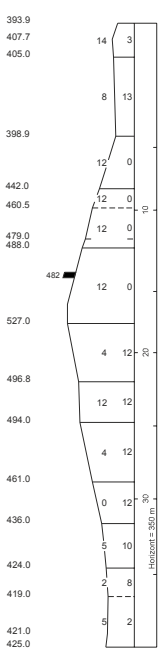

- + Zürich PB S21-24
- + Z Langstrasse
- + Z Hardbrücke
- + Z Altstetten
- + Urdorf
- + Urdorf Weihermatt
- + Mören (Verzw)
- + Birmensdorf Industrie
- + Birmensdorf ZH
- + Bonstetten Nord (Verzw)
- + Bonstetten-W.
- + Bonstetten Süd (Verzw)
- + Hedingen Nord (Verzw)
- + Hedingen
- + Affoltern am Albis
- + Mettmenstetten
- + Knonau
- + Steinhausen
- + vln Luzern
- + Kollermühle (Abzw)
- + Zug Chollernmüll
- + vln Goldau
- + Zug Schutzensel
- + Zug

0.00	
1.90	1.90
2.20	
4.10	
4.41	
8.51	
1.33	9.84
2.17	
0.64	12.01
12.65	
4.64	
17.29	
0.70	18.95
0.96	
1.86	20.81
1.23	22.04
2.73	
24.77	
4.07	
28.84	
2.82	
31.66	
3.00	
34.66	
1.63	36.29
0.23	36.52
1.72	
38.24	
0.65	38.89

vln Thalwil

Baar Lindenpark

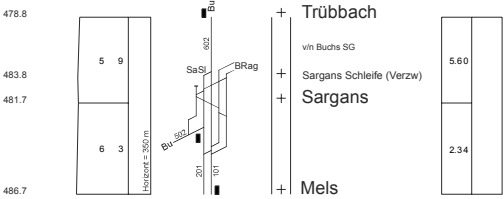

Chur West

vin Reichenau-Tamins

Chur GB

Chur

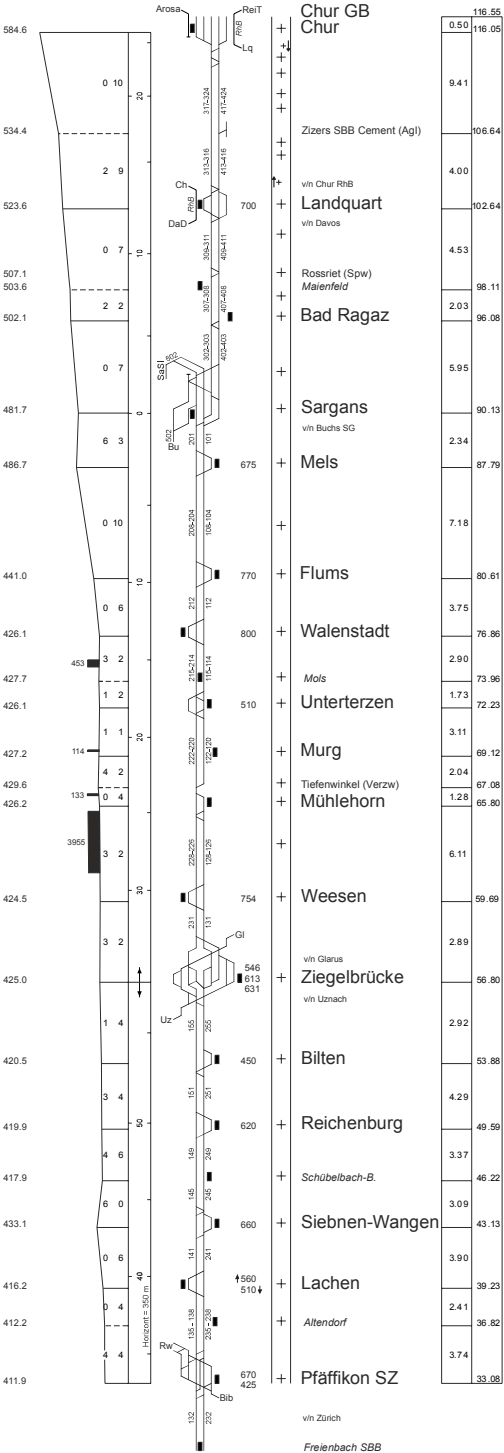

Höhe über Meer RPN = 375.00
 Längsprofil
 Größtes Gefälle
 Größte Steigung
 Kilometerung
 Stationsanlage
 Abzweigungen
 Langste
 Ausweichgleise
 Blickstationen
 Entfernung von Stat. zu Stat.
 Entfernung vom Ausgangspunkt

Freienbach SBB

Rapperswil

Hurden SOB
Pfäffikon SZ Nord (Abzw)

Pfäffikon SZ

vin Samstagern

Freienbach SOB



SBB 65

I-FN-FPA-ROT

09 Dez 2012 - 14 Dez 2013 (Vers 25)

0-12

Pfäffikon SZ

Pfäffikon Nord (Abzw)
Hurden SOB

Rapperswil

v/in Uznach

Blumenau

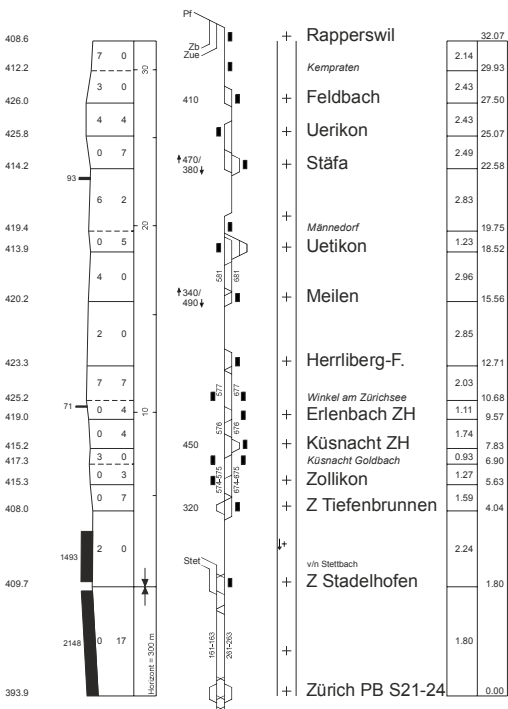
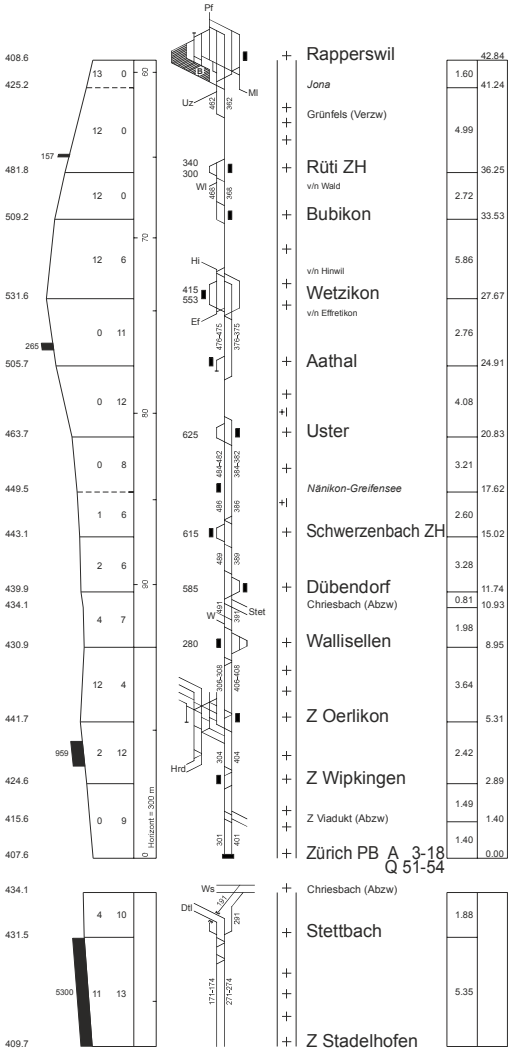

Höhe über Meer (NN) = 373.60
 Längsprofil
 Grosses Gefälle
 Kleines Gefälle
 Horizontale Streckung
 Stationshöhe
 Abzweigungen
 Längsprofile
 Anstiegsrichtung
 Blickabgaben
 v/in Hardbrücke
 Entfernung von Stet. zu Stet.
 Entfernung vom Ausgangspunkt



v/n Rapperswil

Wetzikon

v/n Uster

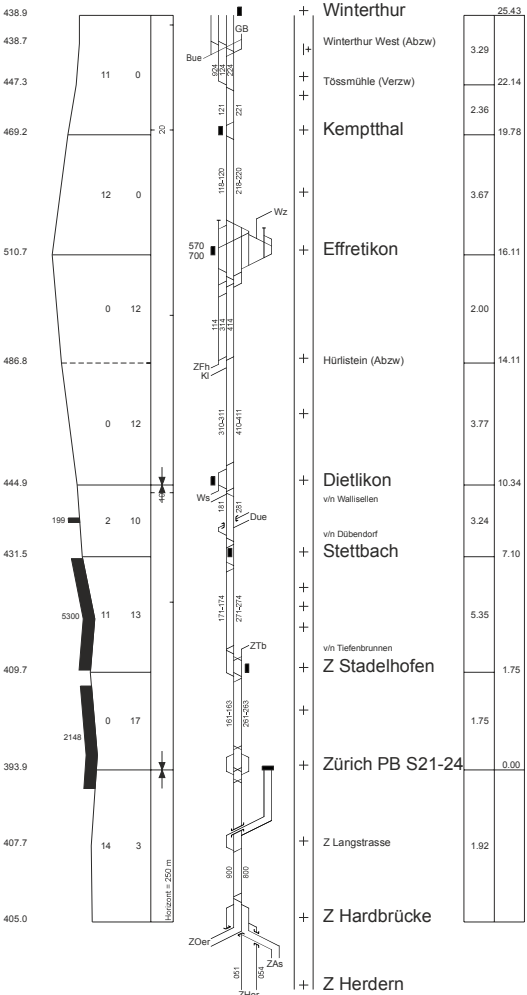
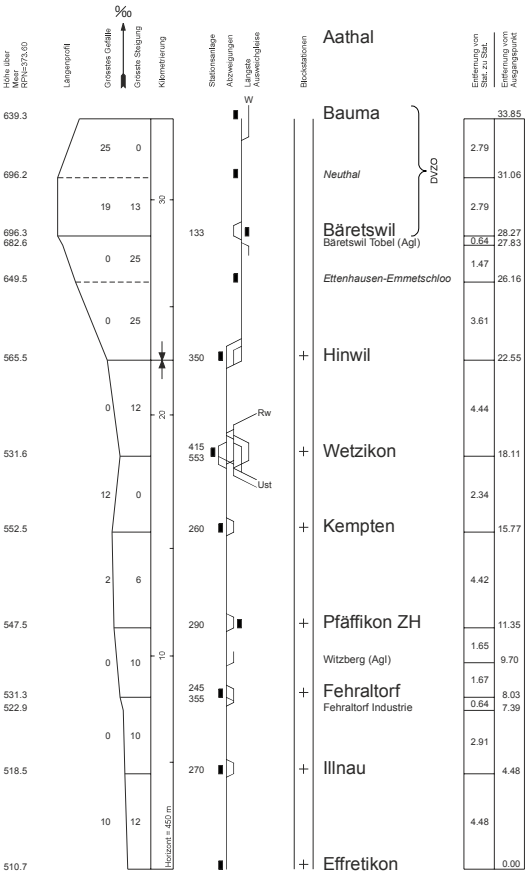

↔ SBB 70 A

I-FN-FPA-ROT
09 Dez 2012 - 14 Dez 2013 (Vers 25)

© SBB Fahrplan und Netzdesign

Winterthur

0-6

Gl. 46

Winterthur West (Abzw)

Links über Meer RPN=373,80
Langensprofil
Grösstes Gefälle
Grösste Steigung
Kilometerleistung

Stationsanlage
Abzweigungen
Langtate
Auswechselliste

Brückennamen

Entfernung von Star. zu Stat.
Entfernung vom Ausgangspunkt

Winterthur GB

Winterthur West (Abzw)

Winterthur Grüze

v/n St. Gallen
Bauma

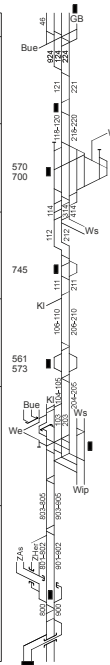
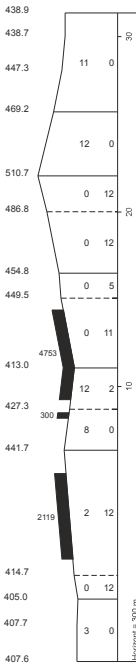

+	Winterthur Gl. 45 / 44 / 43 Winterthur West (Abzw)	31.33
+	Tössmühle (Verzw)	28.04
+	Kempththal	25.68
+	Effretikon	22.01
+	Hürlestein (Abzw)	20.01
+	Bassersdorf	16.54
+	Dorfneft (Abzw)	15.05
+	Z Flughafen	11.11
+	Opfikon Opfikon Süd (Abzw)	8.80 8.13
+	Z Oerlikon	6.35
+		3.08
+	Hard Käferberg (Abzw)	3.27
+	Z Hardbrücke	1.92
+	Z Langstrasse	0.92
+	Zürich PB A3-18	0.00

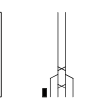
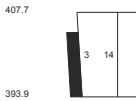

+	Z Langstrasse	0.92
+	Zürich PB S21-24	

Illnau

v/n Wetzikon

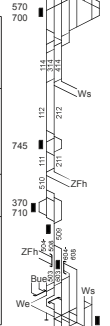
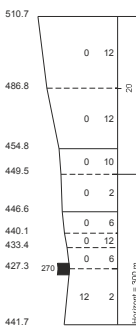

+	Effretikon	22.01
+	Hürlestein (Abzw)	20.01
+	Bassersdorf	16.54
+	Dorfneft (Abzw)	7.38
+	Kloten	5.26
+	Kloten Balsberg Riet (Verzw)	4.05 3.43
+	Opfikon Opfikon Süd (Abzw) v/n Seebach	2.45 1.78
+	Z Oerlikon	0.00

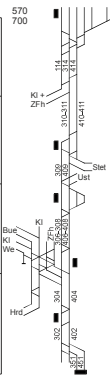
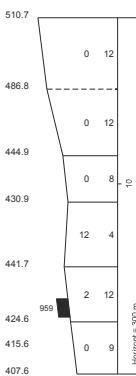

+	Effretikon	17.40
+	Hürlestein (Abzw)	15.40
+	Dietlikon v/n Stettbach	11.63
+	Wallisellen v/n Uster	8.95
+	Z Oerlikon	5.31
+	Z Wipkingen	2.89
+	Z Viadukt (Abzw) Gl. 351 / 451	1.40
+	Zürich PB A3-18 Q51-54	0.00

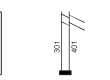
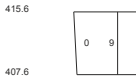

+	Z Viadukt (Abzw)	1.40
+	Zürich PB A3-18 Q51-54	

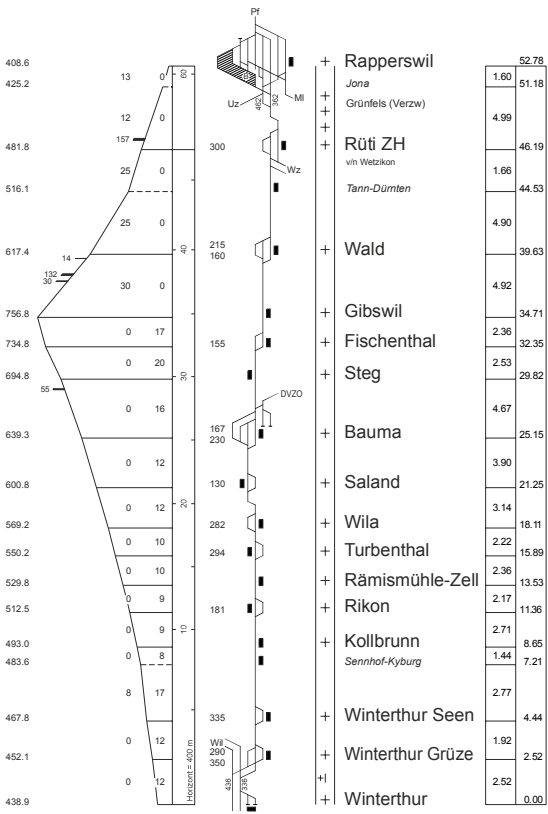

SBB 71 St. Gallen GB

I-FN-FPA-ROT

09 Dez 2012 - 14 Dez 2013 (Vers 25)

St. Gallen West

SG St. Fiden

0-12

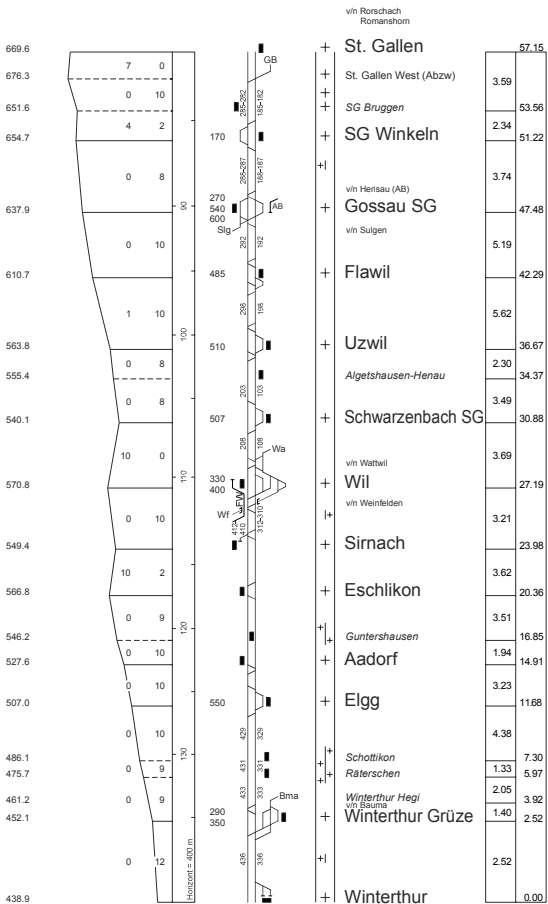

Höhe über Meer RPN+373.00

Längsprofil

Grösste Gefälle

Grösste Steigung

Kilometrierung

Stationenlänge
Abzweigungen
Längste
Anfahrtslänge

Blockstationen

Entfernung von SBB zu SBB
Entfernung vom Ausgangspunkt

vin Zürich

Winterthur West

Winterthur

Winterthur GB

I-FN-FPA-ROT

09 Dez 2012 - 14 Dez 2013 (Vers 25)

0-12

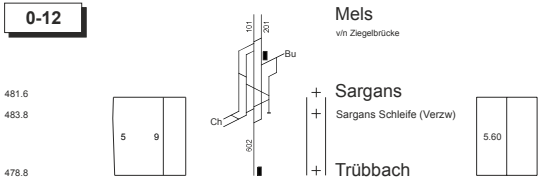

Mels
vln Ziegelbrücke

+ **Sargans**
Sargans Schleife (Verzw)

+ **Trübbach**

5.60	
------	--

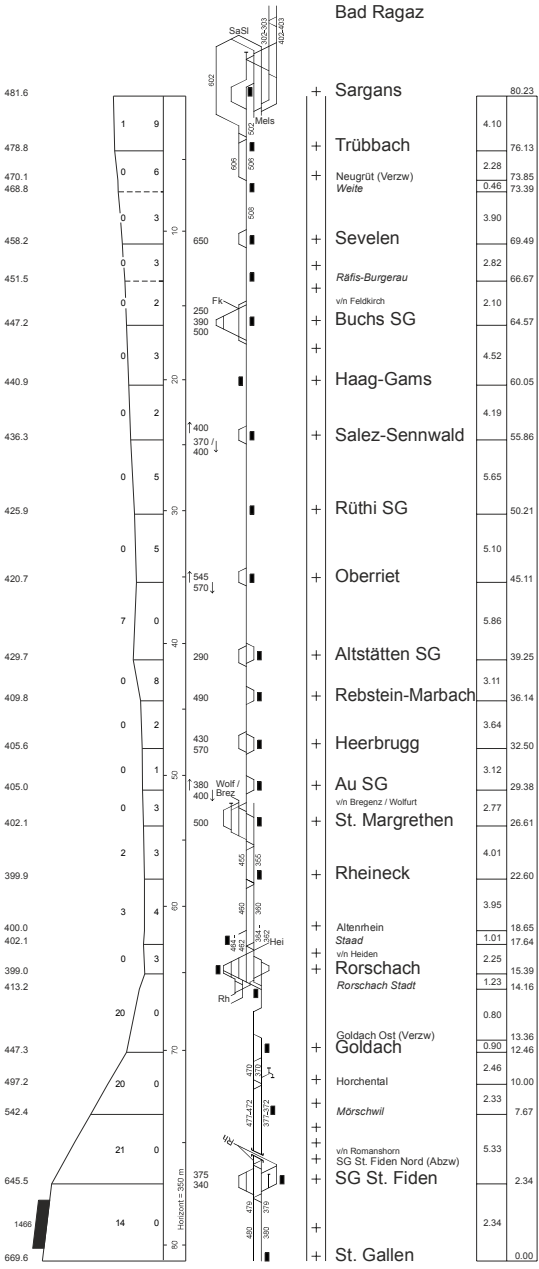

Bad Ragaz

+ **Sargans**

+ **Trübbach**

+ Neugrüt (Verzw)
Weite

+ **Sevelen**

+ *Räfis-Burgerau*
vln Feldkirch

+ **Buchs SG**

+ **Haag-Gams**

+ **Salez-Sennwald**

+ **Rüthi SG**

+ **Oberriet**

+ **Altstätten SG**

+ **Rebstein-Marbach**

+ **Heerbrugg**

+ **Au SG**
vln Bregenz / Wolfurt

+ **St. Margrethen**

+ **Rheineck**

+ **Altenhein**
Staad
vln Heiden

+ **Rorschach**
Rorschach Stadt

+ **Goldach Ost (Verzw)**
Goldach

+ **Horchentail**

+ **Mörschwil**

+ **SG St. Fiden**
vln Romanshorn
SG St. Fiden Nord (Abzw)

+ **St. Gallen**
vln Gossau SG

80.23	
4.10	
76.13	
2.28	
73.85	
0.46	
73.39	
3.90	
69.49	
2.82	
66.67	
2.10	
64.57	
4.52	
60.05	
4.19	
55.86	
5.65	
50.21	
5.10	
45.11	
5.86	
39.25	
3.11	
36.14	
3.64	
32.50	
3.12	
29.38	
2.77	
26.61	
4.01	
22.60	
3.95	
18.65	
1.01	
17.64	
2.25	
15.39	
1.23	
14.16	
0.80	
13.36	
0.90	
12.46	
2.46	
10.00	
2.33	
7.67	
5.33	
2.34	
2.34	
0.00	

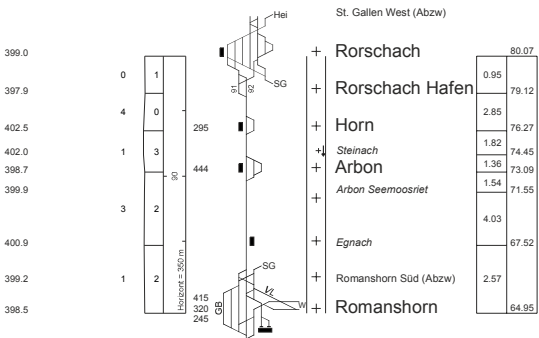

St. Gallen West (Abzw)

+ **Rorschach**

+ **Rorschach Hafen**

+ **Horn**

+ *Steinach*

+ **Arbon**

+ *Arbon Seemoosriet*

+ **Egnach**

+ **Romanshorn Süd (Abzw)**

+ **Romanshorn**

80.07	
0.95	
79.12	
2.85	
76.27	
1.82	
74.45	
1.36	
73.09	
1.54	
71.55	
4.03	
67.52	
2.57	
64.95	

‰

Grösste Carlatä
 Grösste Steigung
 Kilometerung
 Stationsanlege
 Abzweigungen
 Längste
 Ausweichgleise
 Blockstationen

Entfernung von
 Bauk.zu Bauk.
 Entfernung vom
 Ausgangspunkt

Romanshorn Süd (Abzw)

Romanshorn GB

Romanshorn



SBB 73

I-FN-FPA-ROT

09 Dez 2012 - 14 Dez 2013 (Vers 25)

0-12

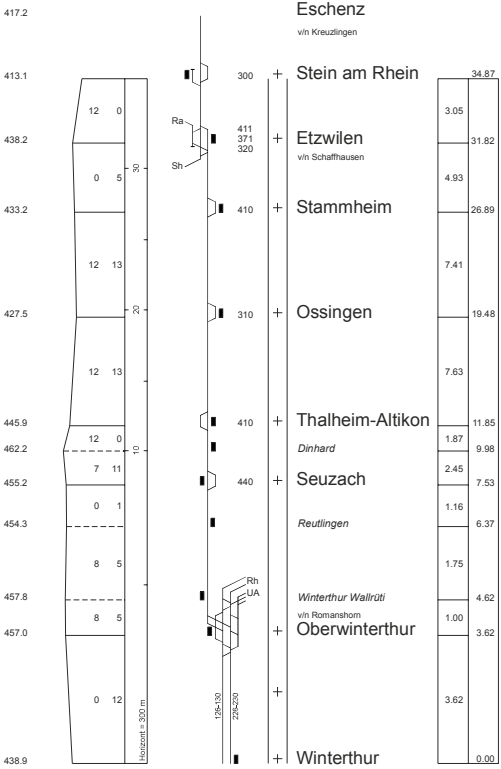

Winterthur GB

Schaffhausen GB

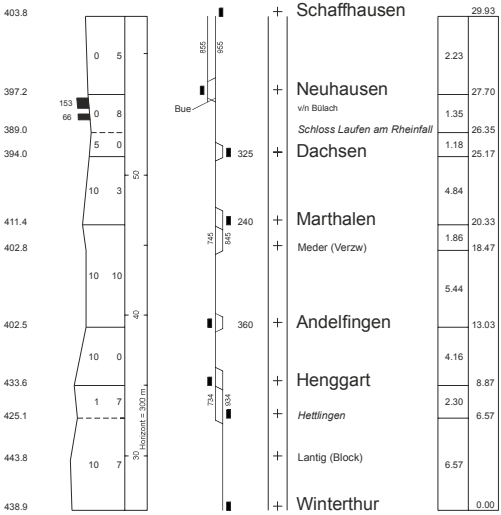

Winterthur GB

Höhe über Meer
RPN=373,00

Langenprofil
Größtes Gefälle
Größte Steigung
Kilometertrung

Stationsanlage
Abzweigungen
Langgäte
Ausweichgleise

Blockstationen

Entfernung von Stat. zu Stat.
Entfernung vom Ausgangspunkt



SBB 74

I-FN-FPA-ROT

09 Dez 2012 - 14 Dez 2013 (Vers 25)

St. Gallen GB

0-12

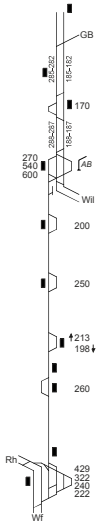
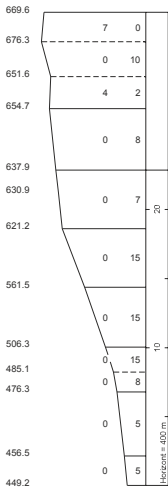

St. Gallen West (Abzw)		32.62
+	St. Gallen	
+	St. Gallen West (Abzw)	1.05 31.57
		2.54
+	St. Gallen Bruggen	29.03
		2.34
+	SG Winkeln	26.69
		3.74
+	Gossau SG	22.95
	Gossau Sommerau (Agl)	4.36
+	Arnegg	18.59
		4.21
+	Hauptwil	14.38
		4.33
+	Bischofszell Stadt	10.05
	Sitterdorf	1.85 8.20
+	Bischofszell Nord	1.42 6.78
		4.66
+	Kradolf	2.12
		2.12
+	Sulgen	0.00

Romanshorn Süd (Abzw)

v/n Rorschach
Romanshorn

Uttwil

Romanshorn Süd (Abzw)

Romanshorn VL

Romanshorn West (Abzw)

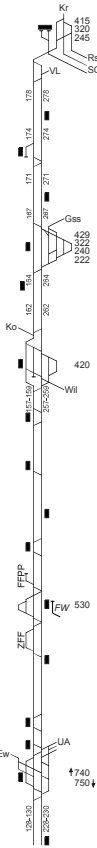
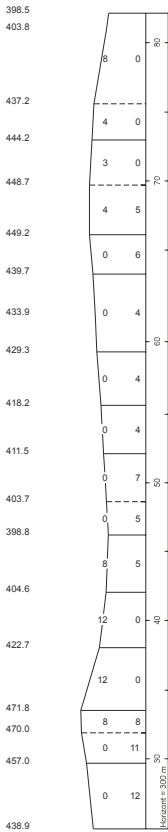

+	Romanshorn	56.12
	Romanshorn West (Abzw)	6.57
+	Amriswil	49.55
		2.67
+	Oberaach	46.88
		3.21
+	Erlen	43.67
	v/n Gossau	3.60
+	Sulgen	40.07
		2.83
+	Bürglen	37.24
		1.99
	Weinfeld KVA TG (Agl)	35.25
	v/n Konstanz	1.80
+	Weinfeld	33.45
	v/n Wil	3.80
+	Märstetten	29.65
		3.57
+	Müllheim-Wigoltingen	26.08
		3.45
	Hüttlingen-Mettendorf	22.63
+	Felben-Wellhausen	20.16
		2.47
	v/n Frauenfeld Paketpost	4.14
+	Frauenfeld	16.02
		4.00
+	Islikon	12.02
		4.52
+	Rickenbach-Attikon	7.50
	Wiesendangen	1.61 5.89
	v/n Etzwilen	2.27
+	Oberwinterthur	3.62
		3.62
+	Winterthur	0.00

v/n Zürich

Winterthur West (Abzw)

Höhe über Meer (NN) 373.60
 Längsprofil
 Grösstes Gefälle
 Grösste Steigung
 Klimoneigung
 Stationsanlage
 Abzweigungen
 Langste Anfahrstrecke
 Blockstationen
 Entfernung von St. zu Stab.
 Entfernung zum Ausgangspunkt

Unterhaltsanlage

Oberwinterthur

Winterthur

Winterthur GB



SBB 75

I-FN-FPA-ROT

09 Dez 2012 - 14 Dez 2013 (Vers 25)

Schwarzenbach SG

0-12

vin St. Gallen

Wil

vin Winterthur

Sirnach

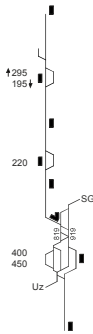
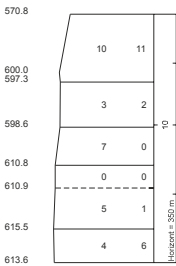

+	Wil	20.00
	Bazenheid ZAB (Agl)	5.90
+	Bazenheid	14.10
		1.02
		13.08
		3.23
+	Lütisburg	9.85
		2.77
+	Bütschwil	7.08
	Dietfurt	1.69
		5.39
+	Lichtensteig	2.90
		2.49
+	Wattwil	2.49
	vin Nesslau	0.00
+	Ebnat-Kappel	

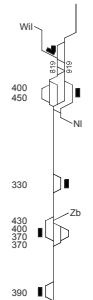
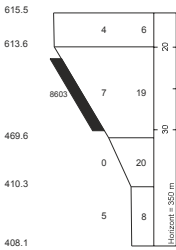

+	Brunnadern-Neckertal	
	vin St. Gallen	
+	Lichtensteig	
+	Wattwil	27.18
		10.98
+	Kaltbrunn	16.20
	vin Ziegelbrücke	3.40
+	Uznach	12.80
		2.83
+	Schmerikon	9.97

Weesen

vin Sargans

Ziegelbrücke

vin Zürich

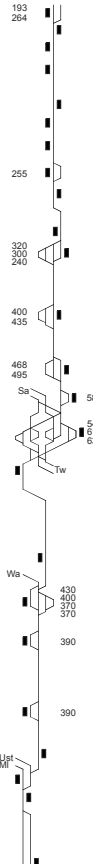
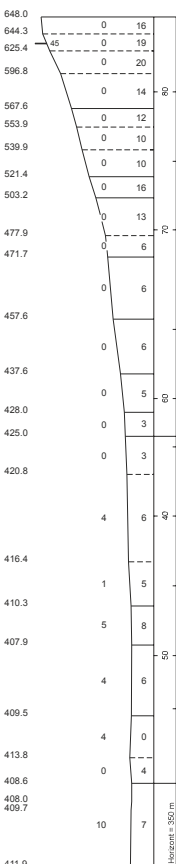
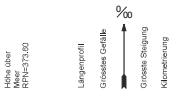

+	Bitlen	
	Entfernung von Stat. zu Stat.	
	Entfernung vom Ausgangspunkt	
+	Linthal	52.28
	Linthal Braunwaldbahn	0.40
	Rüt GL	1.20
		50.68
	Diesbach-Betschwanden	1.60
		49.08
+	Luchsingen-Hätzingen	2.57
	Leuggelbach	1.31
		45.20
	Nidfurn-Haslen	1.60
		43.60
+	Schwanden	1.96
		41.64
+	Mitlödi	1.55
		40.09
	Ennenda	2.78
+	Glarus	37.31
		0.88
		36.43
		2.97
+	Netstal	33.46
		3.98
+	Näfels-Mollis	29.48
		2.74
+	Nieder- und Oberumen	26.74
	Ziegelbrücke	1.76
		24.98
	Schänis	2.77
		22.21
		6.29
	Benken	15.92
	vin Wattwil	3.12
+	Uznach	12.80
		2.83
+	Schmerikon	9.97
		5.09
+	Bollingen	4.88
	Blumenau	3.01
		1.87
+	Rapperswil	1.87
	Hurden	0.00
	Pfäffikon SZ Nord (Verzw)	4.05
+	Pfäffikon SZ	



0-12

Weinfelden

via Winterthur

Märstetten

Kurzrickenbach Seepark

via Romanshorn

Kreuzlingen Hafen

Kreuzlingen

Kreuzlingen Hafen
Kreuzlingen Hafen Grenze

Konstanz

Singen (Htw)

Radolfzell

DB

Konstanz

42.31

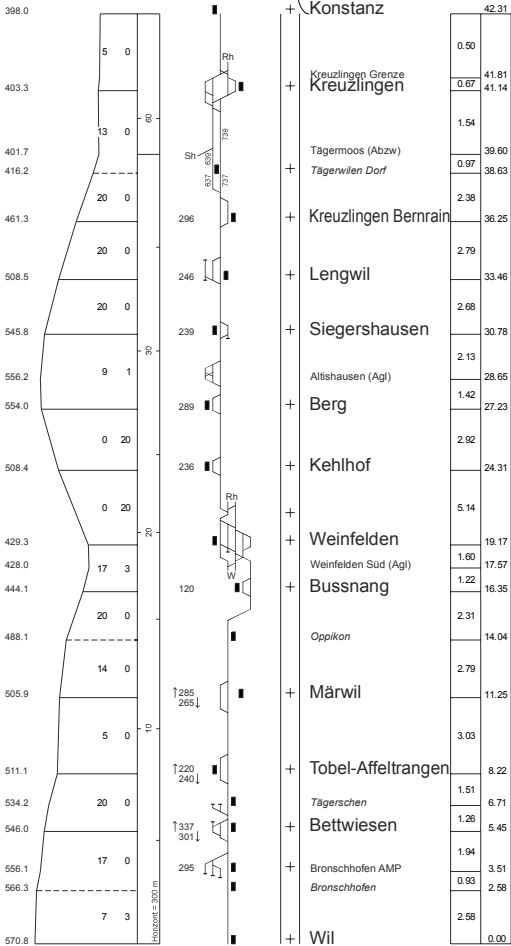

Höhe über RPN=373.00
Längsprofil
Gründer Carfelle
Gründer Steigung

Stationenlänge
Abzweigungen
Länge
Ausweichphase

Blockstationen

Entfernung von Sbz zu Sbz
Entfernung vom Ausgangspunkt

via Wattwil

Bazenheid

Sirnach

via Winterthur

Wil

via St. Gallen

Schwarzenbach SG

I-FN-FPA-ROT

09 Dez 2012 - 14 Dez 2013 (Vers 25)

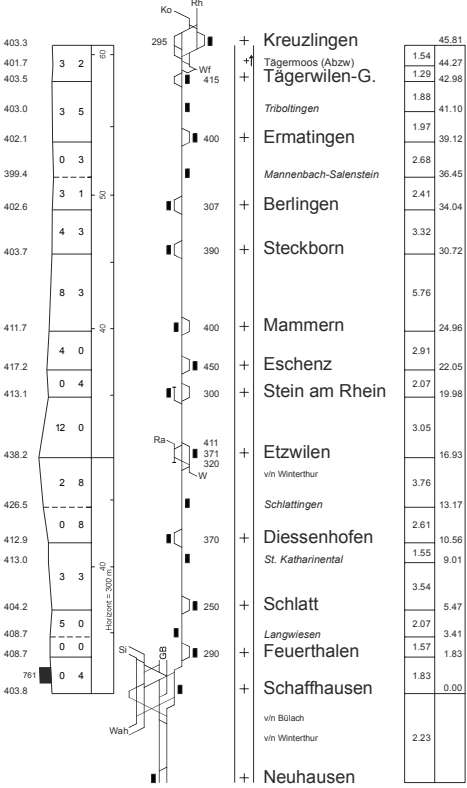
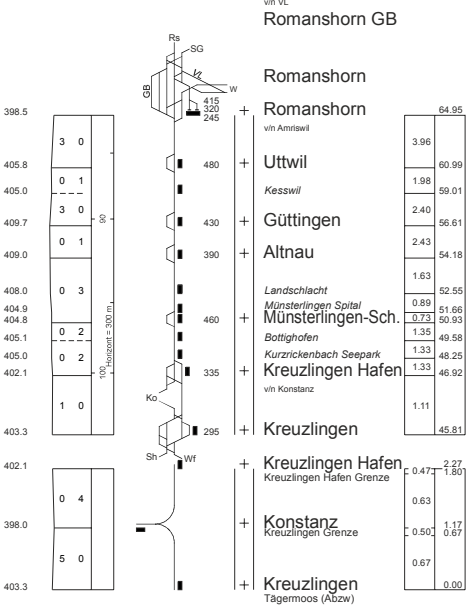
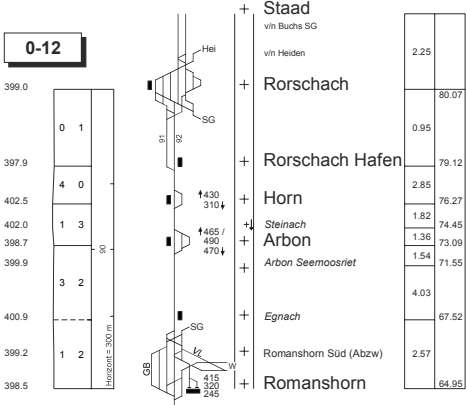

Höhe über Meer RPN=373.00
Längsprofil
Gleises Gürtel
Abzweigung
Gleise Steigung
Kilometerung

Stationslage
Abzweigungen
Längs-
Anweichgleise

Blockstationen

Entfernung von
Stad. zu Stad.
Entfernung vom
Ausgangspunkt

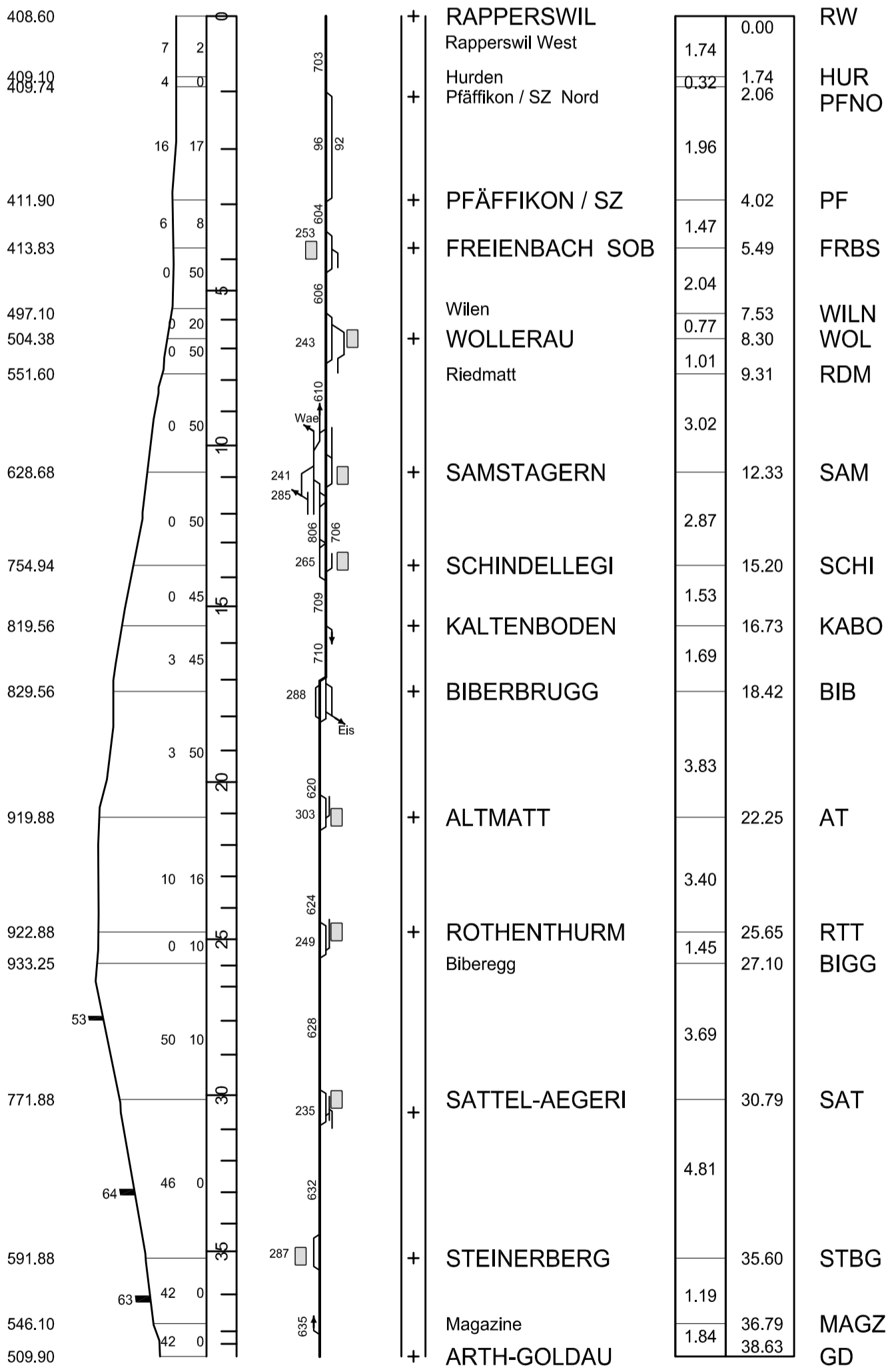
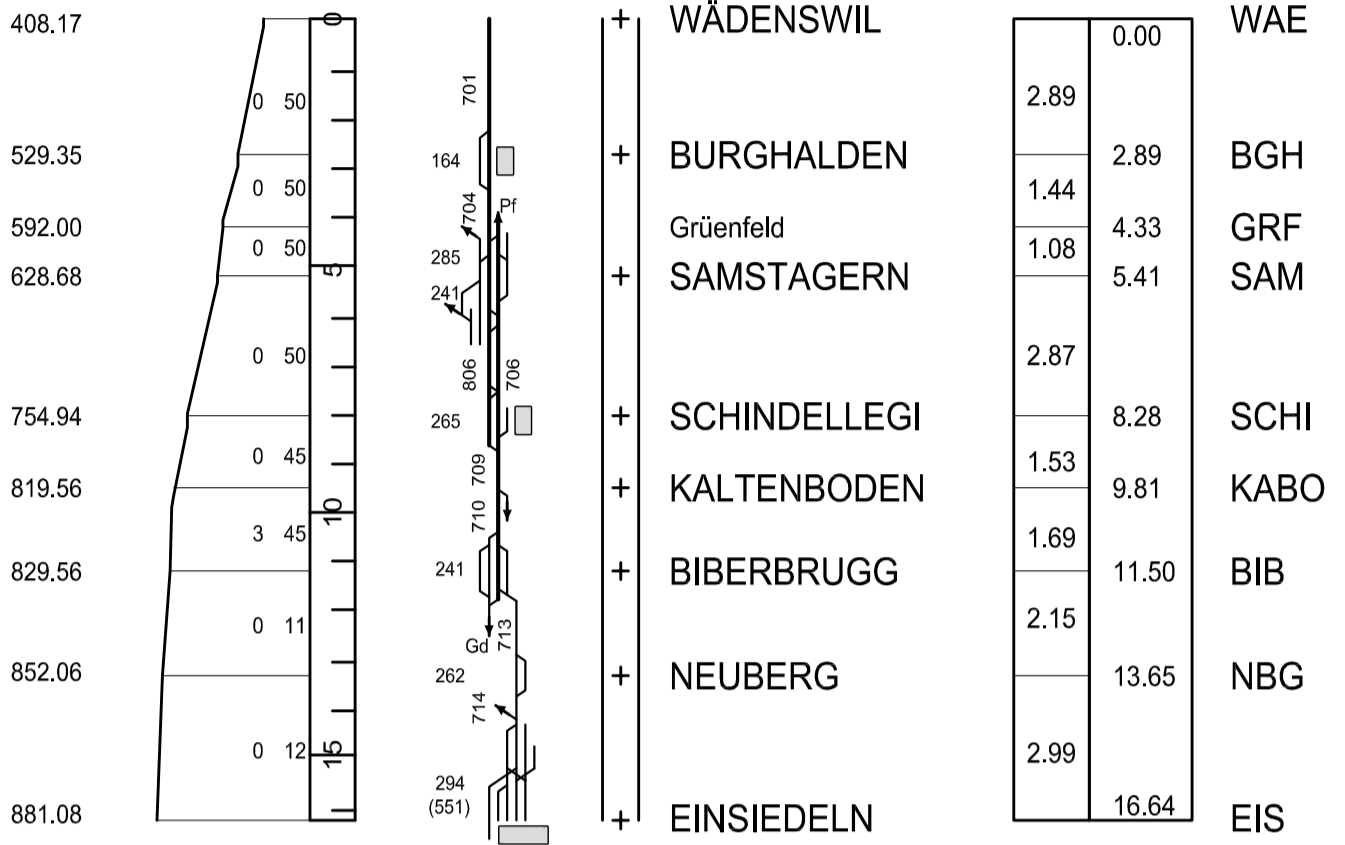

Höhen über Meer
RPN=373.60
Meter

Längenprofil

Grösstes Gefälle
% Grösste Steigung
Kilometrierung

Stationslage,
Abzweigungen,
Längste Ausweichgleise
Streckengleisbezeichnung

Blockstationen

Entfernung zwischen
den Betriebspunkten
Entfernung vom
Ausgangspunkt
km

SOB SÜDOSTBAHN

79

09. Dez. 2012 - 14. Dez. 2013

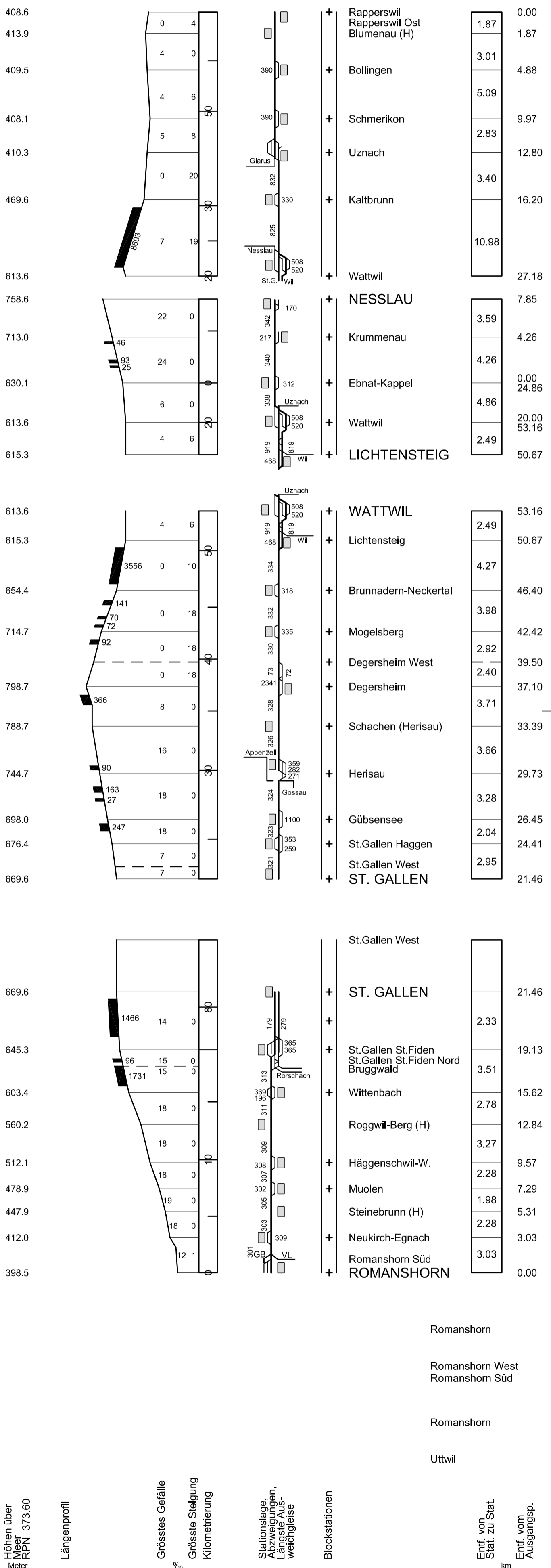

Höhen über Meer
RPN=373.60
Meter

Längenprofil

Grösstes Gefälle
Grösste Steigung
Kilometrierung

Stationslage,
Abzweigungen,
Längste Aus-
weiche

Blockstationen

Entf. von Stat. zu Stat.
Entf. vom Ausgangsp.
km

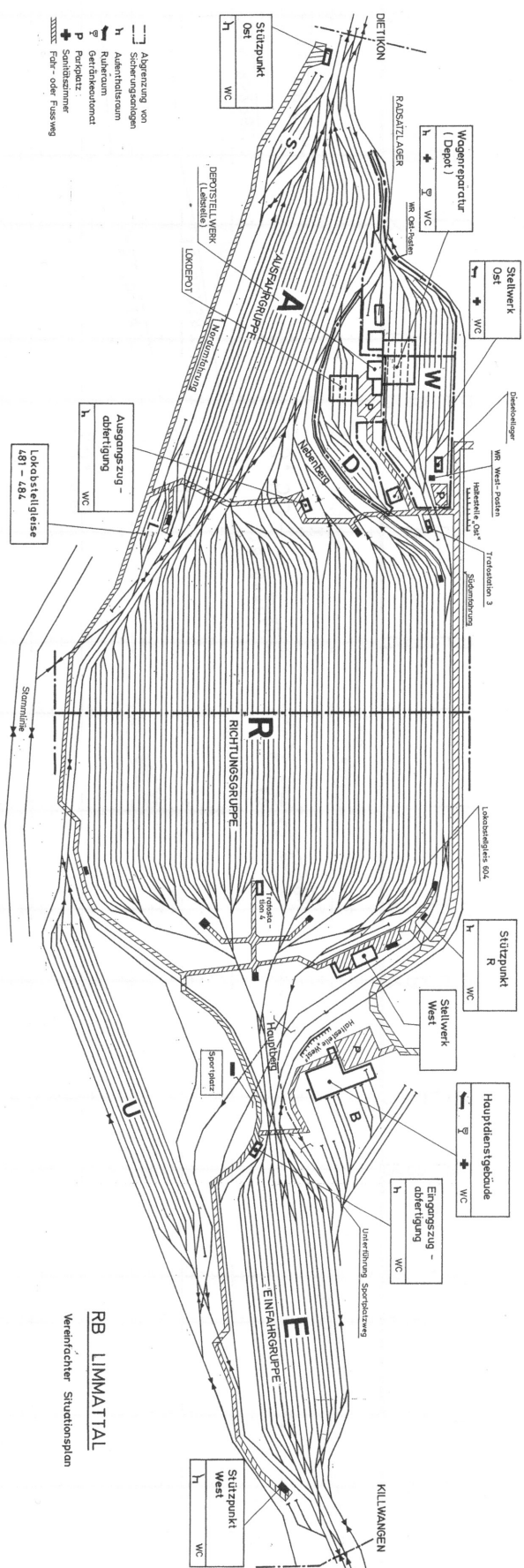

- Abgrenzung von Sicherungszonen
- h Außenhofraum
- g Gerätekoutomat
- P Parkplatz
- + Sanitätszimmer
- xxxxx Fahr- oder Fußweg

RB LIMMATTAL

Vereinfachter Situationsplan

Lokostellgleise
481 - 484

Stammlinie

0 100 200